

ITC-Series Inverter/Charger System

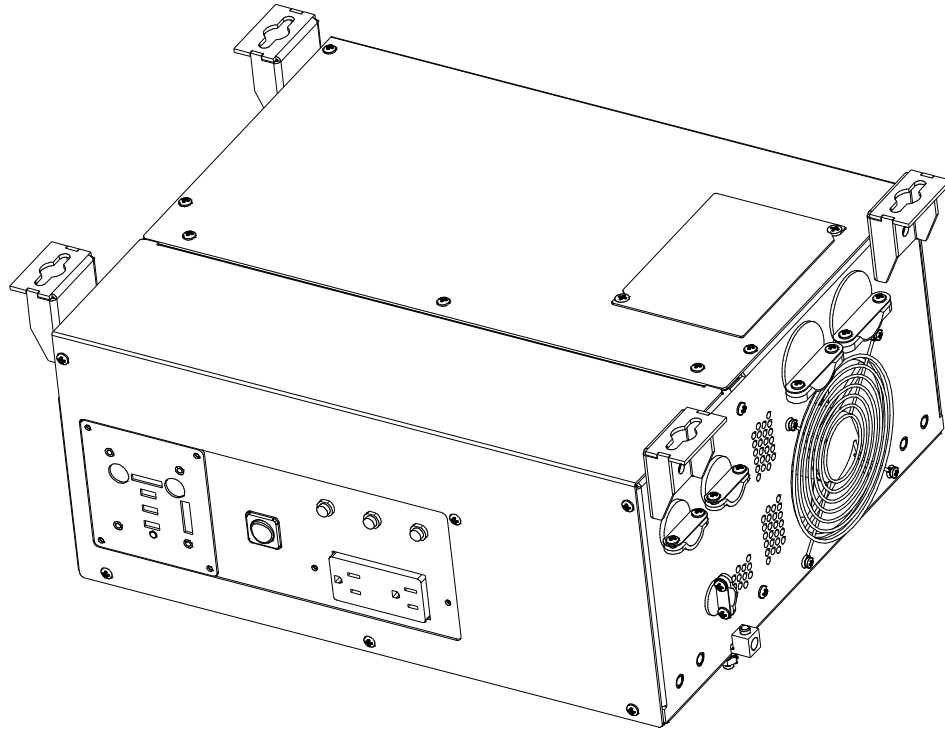

Models ITC12-2100 and ITC12-3200
 ITC24-3600 and SP00172

***Vanner Incorporated
4282 Reynolds Drive
Hilliard, Ohio 43026
(614) 771-2718
1-800-ACPOWER
www.vanner.com***

Owner's Manual D911149
October 7, 2005
File D911149-C.doc

Notes



Table of Contents

SYSTEM FEATURES AND SPECIFICATIONS5

 GENERAL DESCRIPTION5

 SYSTEM FEATURES6

 SPECIFICATIONS.....7

 COMPONENT IDENTIFICATION/LOCATION.....7

DESCRIPTION OF OPERATION.....13

 INVERTER 13

 BATTERY CHARGER..... 14

 BATTERY TEMPERATURE SENSOR OPTION 15

 AUTOMATIC POWER MANAGEMENT (APM) 15

 GENSTART 16

CHARGER AND APM PROGRAMMING.....16

CUSTOMER WIRING IDENTIFICATION17

 AC INPUT & OUTPUT WIRING 18

 DC (BATTERY) WIRING..... 18

 FRONT PANEL CONTROL/DISPLAY OUTLET 18

 SYSTEM ON/OFF SWITCH 19

 REMOTE SIGNAL CONTACTS 19

INSTALLATION.....19

 BASIC GUIDELINES 19

 DC WIRING 20

 AC WIRING 22

 SYSTEM START-UP AND TESTING 23

 BATTERY TEMPERATURE SENSOR 24

GENERAL INFORMATION SECTION.....24

 GENERIC INVERTER DESCRIPTION 24

 INVERTER SIZING..... 25

 DC POWER CONSUMPTION..... 25

 BATTERY TERMINOLOGY AND RATINGS..... 26

 SIZING THE INVERTER BATTERY..... 27

 BATTERY AND CHARGING SYSTEM CONSIDERATIONS 28

 BATTERY CHARGING GUIDELINES 28

MAINTENANCE & TROUBLESHOOTING30

 PREVENTATIVE MAINTENANCE..... 30

Figures

F 1	Figure 1.1-1 System Diagram.....	5
F 2	Figure 1.4-1 Component Location	8
F 3	Figure 1.4-2 ITC Control/Display Unit.....	9
F 4	Figure 1.4-3 ITC Control/Display Unit Component Identification.....	9
F 5	Figure 1.4-4 Suspended Mounting Configuration.....	10
F 6	Figure 1.4-5 Bench Mount Configuration.....	10
F 7	Figure 1.4-6 Suspended Dimensions in Inches.....	11
F 8	Figure 1.4-7 Bottom Mount Dimensions in Inches	11
F 9	Figure 1.4-8 Control/Display Unit Dimensions in Inches	11
F 10	Figure 1.4-9 Customer Terminations.....	12
F 11	Figure 2.2-1 Charging/Voltage Curves	14
F 12	Figure 2.4-1 APM/Charger/Config DIP Switch Settings	17
F 13	Figure 3-1 Customer Terminations.....	17
F 14	Figure 4.1-1 Shelf Mount Configuration.....	20
F 15	Figure 6.1-1 Options Terminal Strip	30

Tables

T 1	Figure 2.2-2 Battery Charger Factory Setpoints.....	15
T 2	Table 4-1 DC Cable and Fuse Sizing Chart	20

Introduction

Thank you for purchasing the Vanner ITC-Series inverter/charger system. We are confident that you will be satisfied with its performance and its many features. With proper installation and care, you can look forward to years of service from this high performance product.

This document will describe the operation, technical specifications and installation procedures for the ITC-Series inverter/charger system. If you require additional information please contact your dealer, or contact Vanner directly at the location shown on the cover of this manual.

System Features and Specifications

General Description

The ITC-Series system consists of a DC to AC true sine wave inverter, a battery charger, an automatic AC transfer switch, and a microprocessor based controller. An important feature of this system is the ITC-Series Control/Display Unit user interface.

ITC Series Inverter System

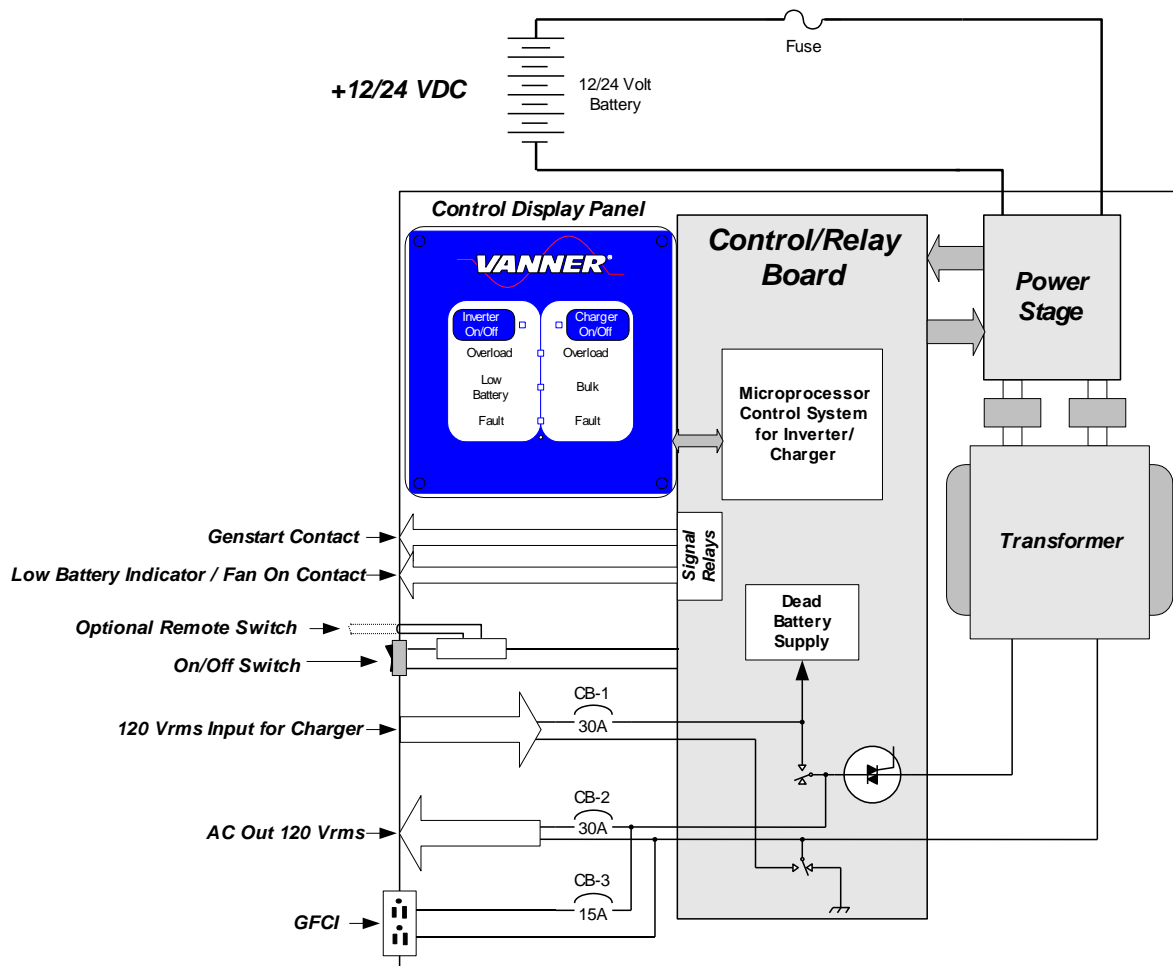

F 1 Figure 1.1-1 System Diagram

System Features

- **Inverter**

The inverter consists of a sine wave inverter that supplies power when AC loads are applied. Depending on your model, the inverter develops 2100, 3200 or 3600 watts of continuous power. Using TruSine® technology, a very high quality sine wave is produced. Total harmonic distortion (THD) is less than 4.0 percent.

- **Battery Charger with Automatic Power Management**

The high efficiency, multi-stage battery charger allows automatic charging of flooded lead acid and gel type batteries. The efficient 0.85 power factor or PF, compared to typical 0.59PF on triac pulse type chargers, allows full charger output from a 30-amp AC source. The system's Bulk, Absorption, and Float charge cycle quickly charges and maintains the battery bank. An Equalization charge cycle is available for flooded lead acid battery maintenance. In addition, there is an optional battery temperature sensor to reduce battery float voltage as temperature increases above 25° Celsius.

Automatic Power Management (APM) monitors the AC Input current and will reduce the battery charger output as needed to keep the AC input current below the preset APM Limit.

- **GenStart Contact**

The GenStart feature provides a start/stop signal to control an automatic generator. The start/stop signal consists of a contact closure to start the Gen. Start based on battery voltage of 12.3 (24.6) VDC. The GenStart turns off when the battery charging current falling below 10 amps.

- **Low Battery or Fan On Contact**

The Low Battery contact allows remote monitoring of the Inverter's battery status. The contact will close when battery voltage falls below 11.0 (22.0) volts. This will alert the user to take appropriate measures to avoid shutdown of the Inverter at 10.5 (21.0) VDC. The SP00172 offers a Fan On contact instead of the Low Battery contact for turning on an external fan or blower when the ITC's fan is on.

- **Remote Power Switch**

This loop between Options Terminal 7 and 8 (left side of Options Terminal) allow remote control of the system On/Off. Tying these two terminals together or optionally, tying the terminal 7 (*Remote Switch*) to battery ground applies power to the unit.

Note: The Front Panel switch will always overrule the remote switch in terms of disabling the unit.

- **System Control**

The ITC contains a System ON/OFF Switch located in the front of the ITC. This switch is used to turn the control power ON and OFF. This power switch also has a break out loop for a series switch that can be placed in a remote location from the unit (See **Remote Power Switch** above). A control microprocessor provides a variety of protection interlocks, system fault detection/reporting/recovery, storage of system data parameters, and high-speed data communications to the ITC Control/Display Unit. This Control/Display Unit also has individual on/off switches for independent Inverter and Charger control. The ITC will protect itself in the event of any overload, over temperature, high or low battery voltage condition.

- **ITC Control/Display Unit**

The ITC Control/Display Unit is a user interface that is connected to the ITC Control Board via a 6-wire modular cable. This Control/Display unit can be an integral part of the Inverter or can be removed and mounted in a remote area to allowing remote system operation. Two of these units can talk to the System Control Board one display would be configured as a Master, and the other as Slave. The configuration switches on top of the Master allow programming of the Charger current, Automatic Power Management and battery type settings.

NOTE: It should be noted that if the Control Display unit is taken out of the front of the unit, the cover plate



Installation

(Vanner Part # D011339) must be installed in it's place to insure that debris does not enter the unit through the opening and to maintain proper airflow through the unit.

Specifications

Model	ITC12-2100	ITC12-3200	ITC24-3600 SP00172
AC OUTPUT			
Voltage (RMS)	120 VAC		
Frequency	60 Hz \pm 0.5%		
AC Waveform	Sine Wave		
Total Harmonic Distortion (THD)	Less than 4.0% @ full power		
Power Factor Allowed	-1 to 1		
Continuous Output Rating @ 25°C			
Phase to Neutral	2100 watts (17.5 amps)	3200 watts (26.7 amps)	3600 watts (30.0 amps)
Surge Capacity @ 25°C (3 sec.)	6400 watts		
DC INPUT:			
Operating Range (12 Volt Nominal)	10.5 to 17 Volts		21.0 to 31 Volts
No Load, Inverter ON	4 amps		3 amps
No Load, Inverter OFF	0.30 amps		0.30 amps
Full power	208 amps	350 amps	195 amps
INVERTER EFFICIENCY @ Nom.			
200 watts	77%		77%
500 watts	88%		84%
700 watts	88%		87%
1000 watts	88%		89%
1500 watts	86%		89%
2000 watts	84%		89%
2500 watts	NA	81%	88%
3000 watts	NA	78%	87%
3200 watts	NA	77%	87%
3600 watts	NA	NA	86%
AC INPUT			
Voltage	120 Volts nominal		
Frequency	60 Hz \pm 12.5% (52.5 to 67.5)		
AC TRANSFER SWITCH			
Power Rating	30 amps @ 120 VAC		
Transfer Time	Less than 40 milliseconds		
BATTERY CHARGER			
Charger Output Current maximum	60, 80 or 110 amps		
AC Input Current maximum	30 amps (0.88PF @ rated output)		
SYSTEM			
Ambient Operating Temperature	-40 to+40°C (-40 to+104°F)		
Cooling Exhaust Fan	Thermostatically controlled		
Mounting	Shelf or suspended		
Dimensions Bottom mount position)	8 1/4"H x 18 7/16"W x 13 5/8"D		
Weight	66 pounds		

Component Identification/Location

The Figures below show the location of the various components of the ITC system.

ITEM #	DESCRIPTION
1	BATTERY TERMINAL ACCESS
2	REMOTE CABLE INPUT
3	CONTROL/DISPLAY PANEL
4	INVERTER ON/OFF SWITCH
5	CHARGER ON/OFF SWITCH
6	SYSTEM ON/OFF SWITCH
7	AC INPUT BREAKER (CB-1)
8	AC OUTPUT BREAKER (CB-2)
9	GFCI BREAKER (CB-3)
10	AC INPUT CABLE ENTRY
11	BATTERY +
12	BATTERY -
13	GFCI OUTLET
14	AC OUTPUT CABLE ENTRY
15	OPTIONS CABLE ENTRY
16	CHASSIS GROUND

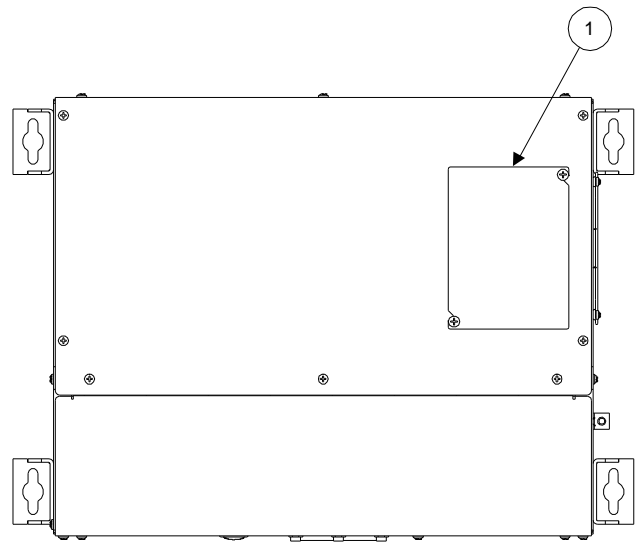

TOP VIEW

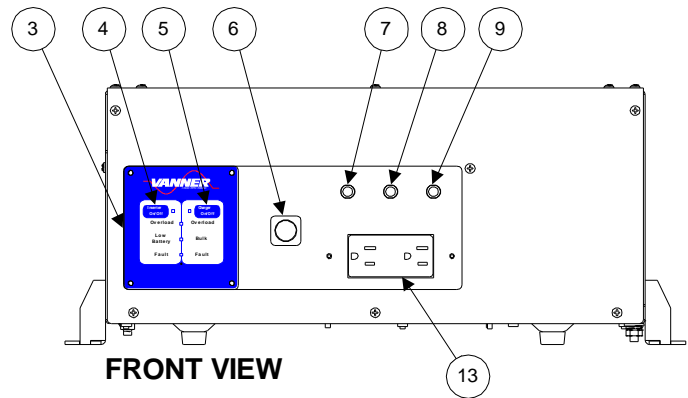

FRONT VIEW

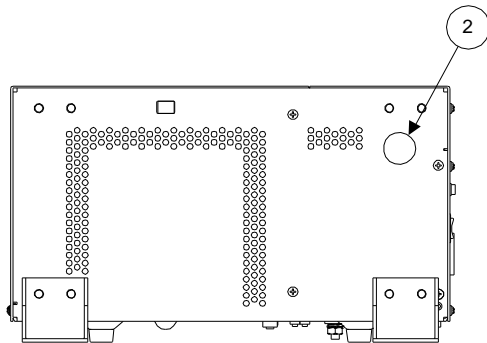

LEFT SIDE VIEW

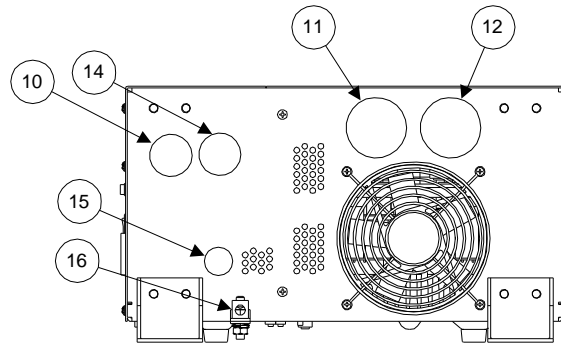

RIGHT SIDE VIEW

F 2 Figure 1.4-1 Component Location

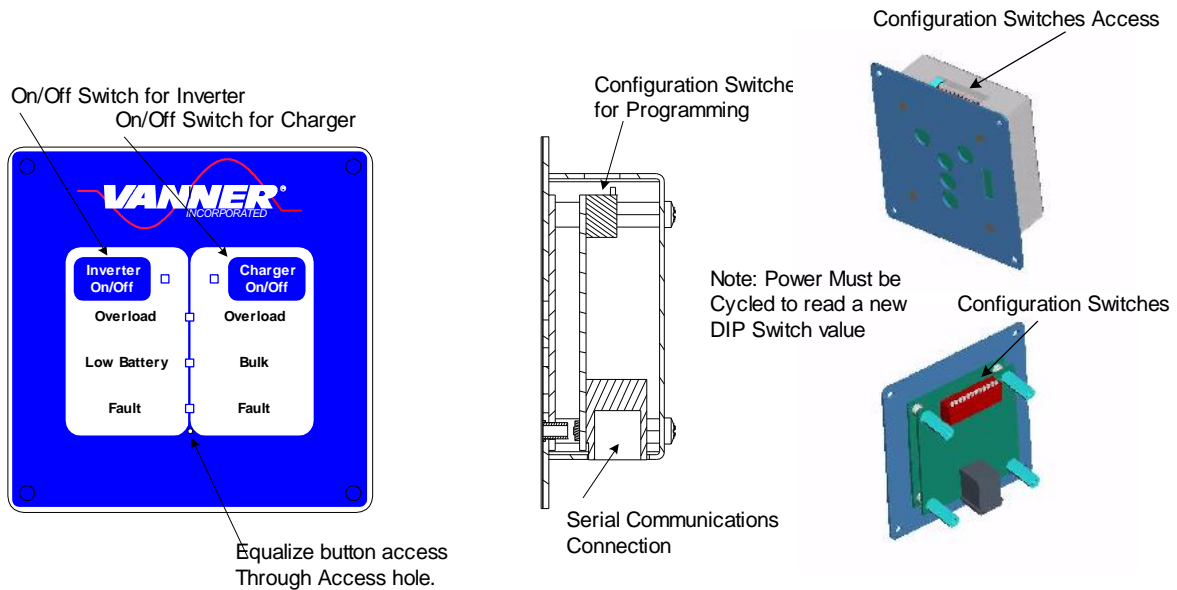

F 3 Figure 1.4-2 ITC Control/Display Unit

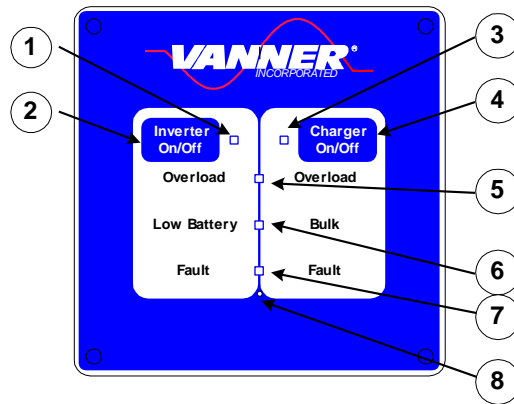

F 4 Figure 1.4-3 ITC Control/Display Unit Component Identification

ITEM	DESCRIPTION
1 Inverter Indicator Light	Solid when on, flashes when enabled but not on
2 Inverter On/Off Button	Enables/Disables Inverter Function
3 Charger Indicator Light	Solid when on, flashes when enabled but not on
4 Charger On/Off Button	Enables/Disables Charger Function
5 Overload Light	Indicates if Inverter Overloaded
6 Low Battery/Bulk Light	Dual Purpose – Indicates Low Battery in Inverter Mode – In charger mode, if on indicates that Charger is in Bulk Mode and if in Equalize, this light flashes.
7 Fault Light	Dual Purpose – Indicates that a fault has occurred in the inverter or Charger – Could be a Over Temperature shutdown, Low/High Battery Shutdown, Power Stage Fault.
8 Equalize Button Access	This is used to enable the equalization cycle on the battery during charging.

Versatile Mounting System

The mechanical system used for mounting the ITC-Series allows both shelf and under-counter mounting, while still allowing access to user AC and control terminals through a removable front cover.

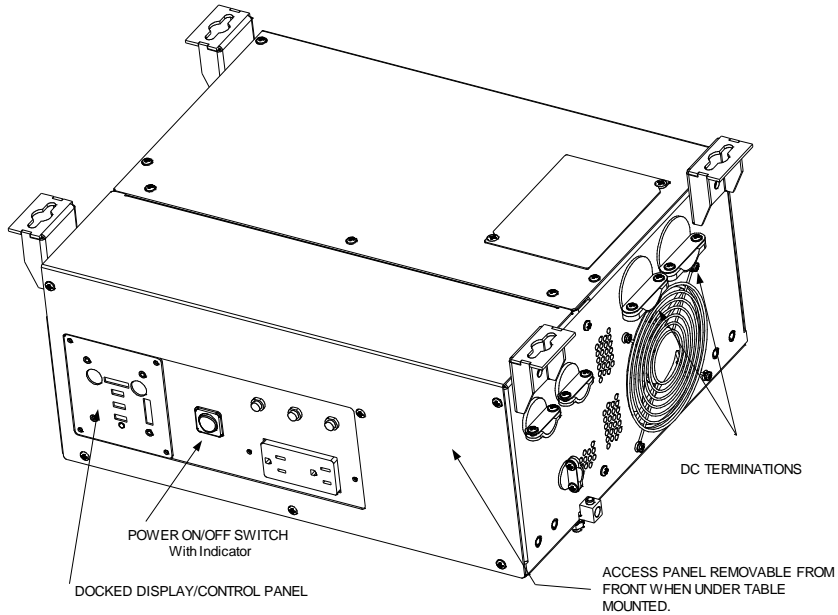

F 5 Figure 1.4-4 Suspended Mounting Configuration

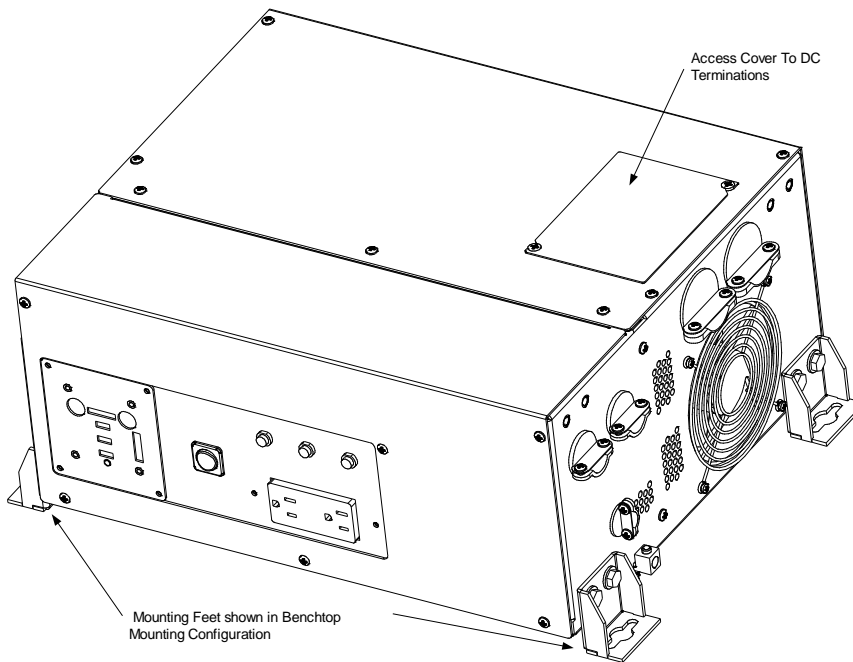

F 6 Figure 1.4-5 Bench Mount Configuration

ITC DIMENSIONS FOR SUSPENDED MOUNTING

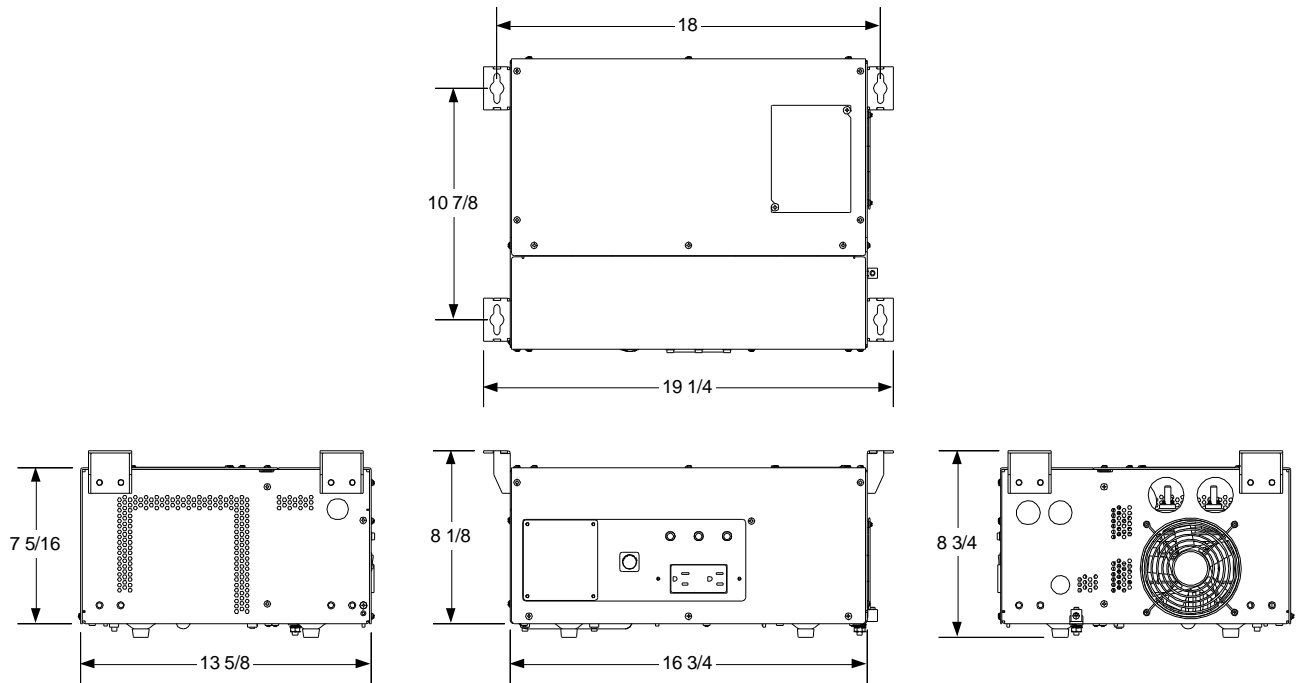

F 7 Figure 1.4-6 Suspended Dimensions in Inches

ITC DIMENSIONS FOR SHELF MOUNTING

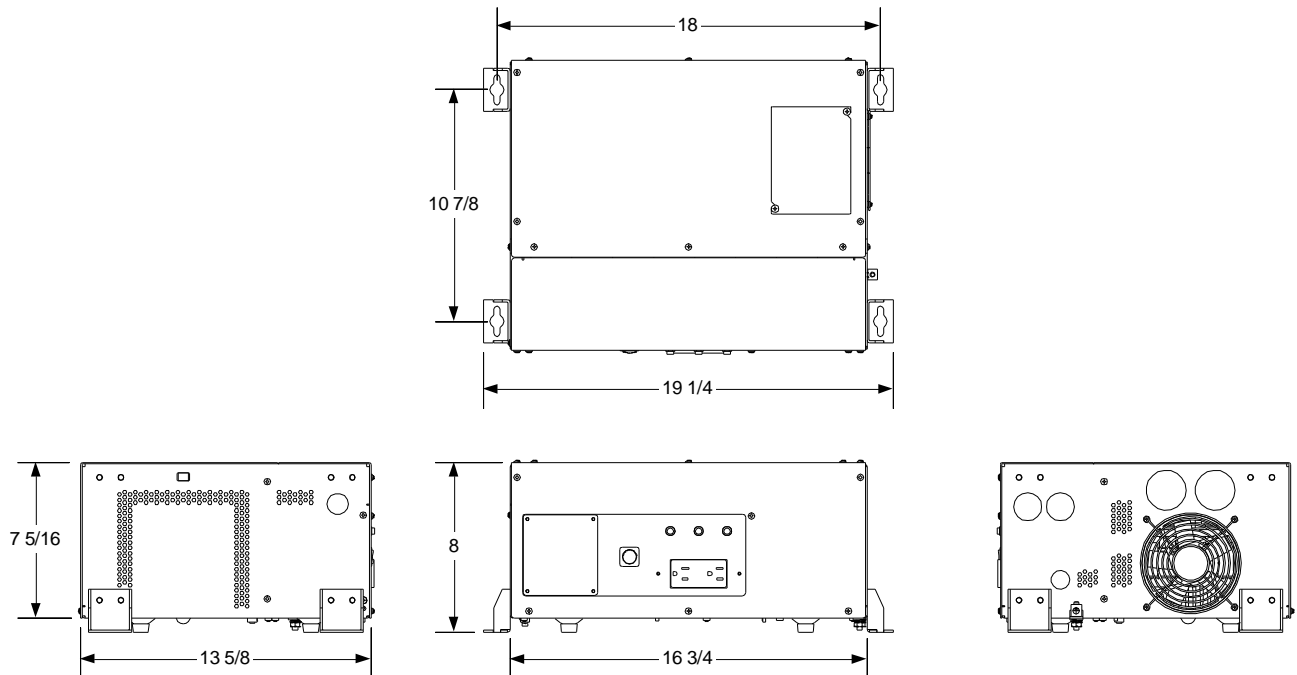

F 8 Figure 1.4-7 Bottom Mount Dimensions in Inches

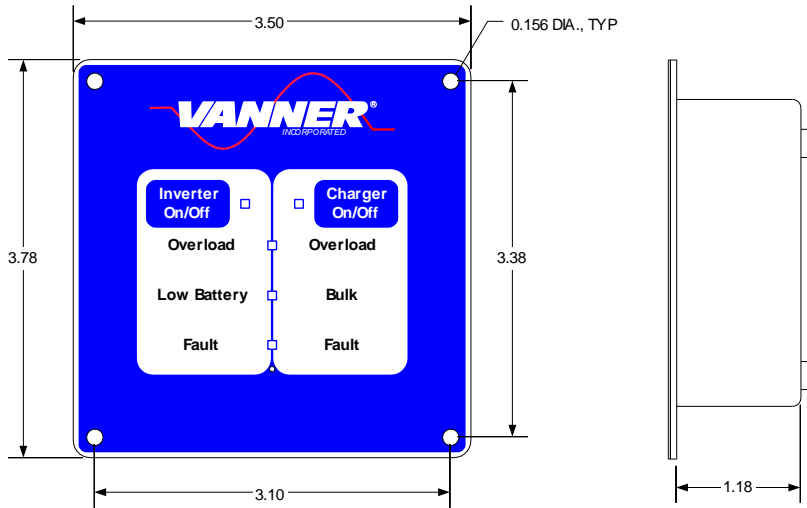

F 9 Figure 1.4-8 Control/Display Unit Dimensions in Inches

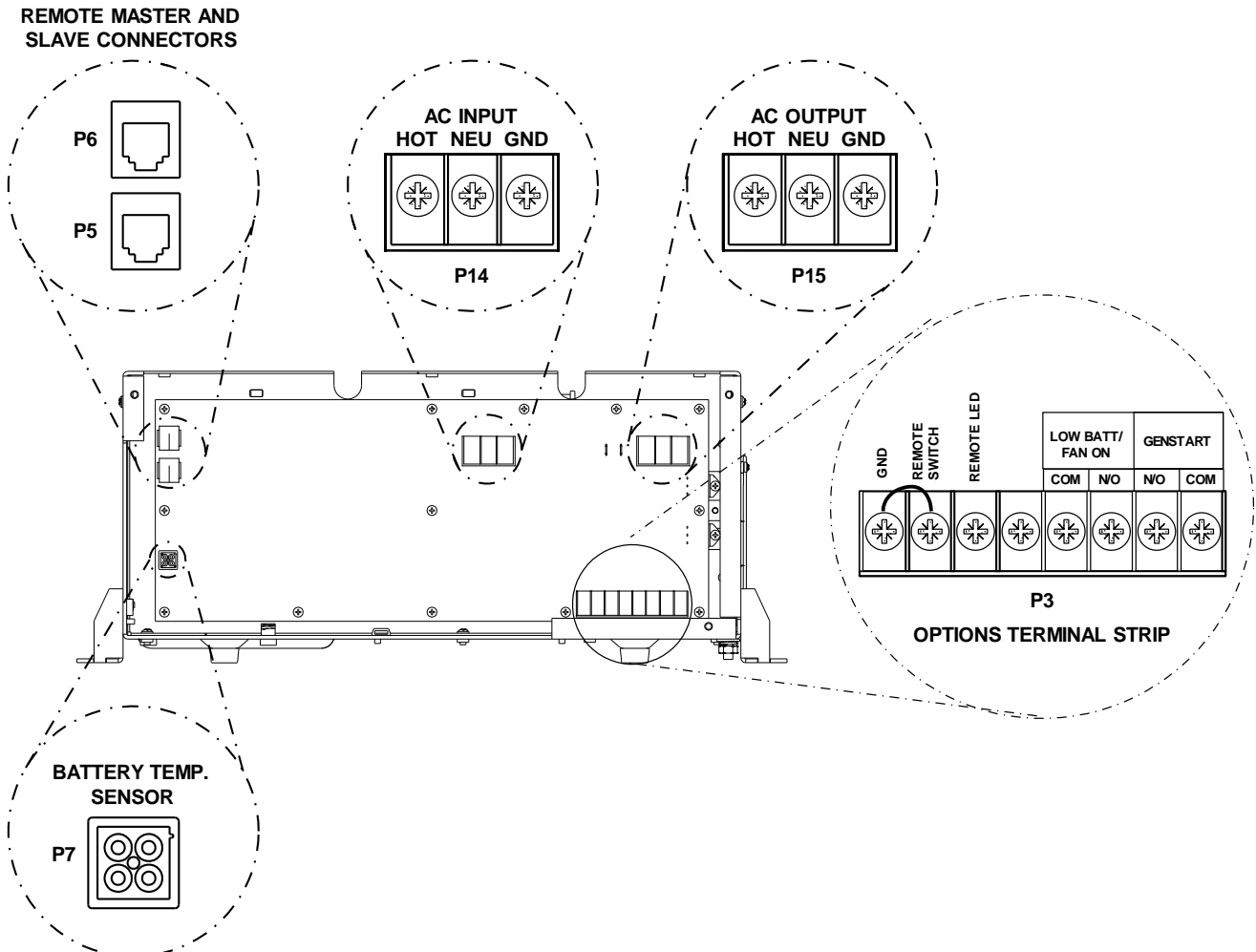

F 10 Figure 1.4-9 Customer Terminations

DESCRIPTION OF OPERATION

Inverter

The System ON/OFF Switch, located on the front panel, allows the user to turn the system power ON and OFF and to reset the system after a fault.

The Charger ON/OFF and Inverter ON/OFF buttons, located on the Control/Display Unit enable or disable the Charger or Inverter Functions. The corresponding light next to Inverter/Charger buttons will be steadily on when the unit is in the Inverter or Charger mode. These Inverter and Charger lights will blink if the mode is not currently on, but are enabled (Example: The Inverter light will blink when the Inverter is Enabled, the ITC is plugged into the utility, and the Charger is Active).

The Inverter AC Output Circuit Breaker is a 1 pole, 30-amp breaker marked “CB-2” on the front unit. The CB-2 breaker protects the Inverter AC output and a second Breaker (CB-1) protects the Battery Charger AC input against a severe overload. This CB-1 breaker also protects AC Pass through Power. If this CB-1 breaker trips during charger operation, it must be reset.

Inverter Protective Interlocks

The Inverter operation is protected by a series of safety interlocks that protect against most failures such as overloads, over-temperature conditions or other conditions where the unit may be asked to operate outside safe battery voltages. These faults will trigger a display of the “Fault” and or “Overload” Lights on the Control/Display panel and are listed below:

Low Battery	The inverter continually monitors battery voltage. If battery voltage falls below the Low Battery Shutdown 10.5 (21.0) VDC setpoint the inverter will shut OFF. Auto-restart will restart the inverter after battery voltage rises above the Low Battery Warning 11.0 (22.0) VDC setpoint (after 5 minutes).
High Battery	The inverter will shut OFF if battery voltage rises above the High Battery 16.0 (31.0) VDC setpoint.
Over Temperature	The inverter will shut OFF if internal temperature sensors detect a high temperature condition that could damage the inverter.
Over Load	If a short circuit or an overload is applied to the inverter’s output the inverter will shut down.
Battery High	The unit has shut down due to the Battery voltage is above High Battery Shutdown setpoint of 16.0 (31.0) VDC.
Battery Low Warn.	Battery voltage is below Low Battery Warning setpoint and soon may reach Low Battery Shutdown setpoint of 10.5 (21.0) VDC.
Current Limit	Inverter AC output current is at the Maximum Current allowed and is presently in “Surge”. The AC voltage will decrease if load increases. Overload Shutdown will occur if voltage goes below 105VAC for 3 second.
Overload	Inverter has shut down due to overload. High AC load caused inverter output voltage to fall below tolerance for three seconds.
Hardware Fault	Internal protection circuit activated or power brick high temperature will shut down system.
Overheat	The SCR plate or power brick overheating will cause the system to shutdown.

If the unit has faulted there are the two following options:

1. Auto-restart After shutting down for any of the above fault conditions, the inverter will try to restart itself every 5 minutes if Auto-Restart is Enabled and the fault condition no longer exists.
2. Manual restart You can manually restart the system after the fault conditions are removed. Reset the inverter by turning the System ON/OFF Switch OFF and then ON.

Battery Charger

The battery charger’s advanced design incorporates an automatic, multi-stage charger. This design enables the unit to automatically charge batteries, which maintains the battery’s integrity and reduces the likelihood of premature battery failure. In addition, the battery charger can utilize the remote battery temperature sensor to reduce the float voltage based on battery temperature. The battery charger is designed to be used with lead-acid type batteries including sealed and gel types, but not for nickel-cadmium (Ni-Cad) or nickel-iron types.

Battery Charging Sequence

Stage 1: Bulk Charge Stage

The charger always starts in the Bulk charge stage each time shore power becomes present and/or each time the charger is turned ON. In the Bulk charge stage, the system charges at the ‘Bulk Charge Amps’ setpoint until the battery voltage rises to the ‘Bulk Charge Voltage’ setpoint. Then the voltage is held at that setpoint until charging current has fallen to 5 amps above the ‘Battery Absorption Amps’. This ends the Bulk Charge Stage and begins the Absorption Charge Stage. The charger will not enter the Bulk Stage again until shore power is re-applied, or until the charger or the system is turned ON again.

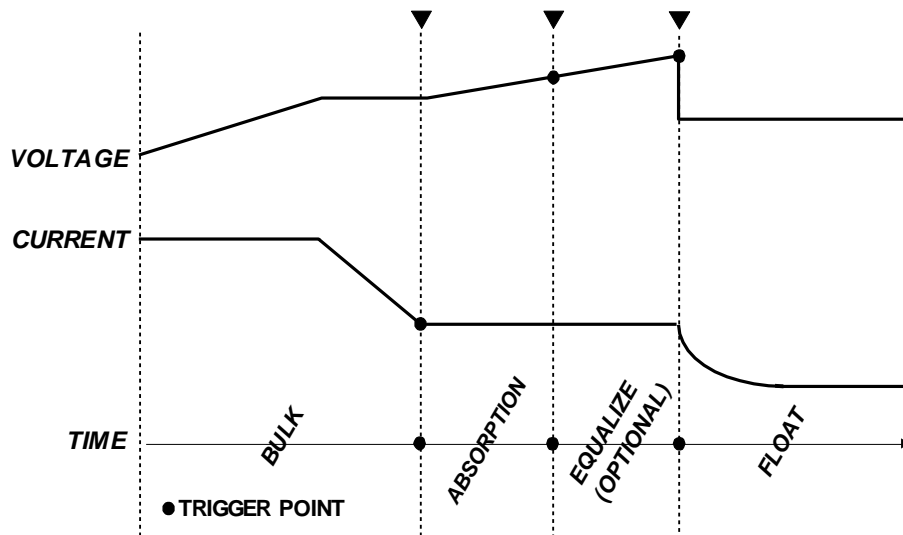

F 11 Figure 2.2-1 Charging/Voltage Curves

Stage 2: Absorption Charge Stage

The Absorption Charge Stage provides a controlled “overcharging” of the battery that is necessary to bring the battery up to full charge. The battery is charged at the ‘Absorption Charge until one of following three conditions occur that signals the end of the Absorption Stage;

Time: The Absorption Maximum Time setpoint is reached

Time: The Absorption Charge Stage time has reached ½ of the duration of the Bulk Charge Stage.

Voltage: Battery voltage reaches the ‘Absorption Voltage’ setpoint

Stage 2A Equalize Charge Cycle

When Equalize Mode is ENABLED (by inserting a paperclip or similar device through the “master” Control/Display unit Equalize hole), one Equalize Charge Cycle will follow the Absorption Charge Stage. The Equalize Cycle will last for the ‘Equalize Time’ setpoint of 15 minutes. Equalize Mode will automatically switch to DISABLED at the end of the Equalize Charge Cycle. During the Equalize Cycle the battery is charged at the

'Absorption Charge Amps' setpoint and the Equalize Voltage 15.5 (30.0) VDC setpoint.

The Equalize Charge Cycle provides a deliberate overcharging of the battery to remove sulfate, which accumulates on the battery plates through normal use. Equalizing returns battery cells to equal performance levels, which improves battery performance and extends battery life. Consult the battery manufacturer for their recommendation regarding how often the Equalize Cycle should be performed.

CAUTION

Do not equalize sealed (valve regulated lead acid, AGM or gel) batteries! Consult battery manufacturer for equalizing guidelines. Do not equalize more often than approximately once a month. Check battery fluids after equalizing is complete, as gassing will occur. Use Equalize Mode only if batteries are in a well ventilated area!

Stage 3: Float Charge Stage - Maintenance Mode

In the Float Stage the charging voltage is reduced to the 'Float Charge Voltage' setpoint and charging current is limited to the 'Absorption Charge Amps' setpoint. The charger will remain in the Float Stage until shore power is reapplied, or until the charger or system is turned OFF and then ON again.

Charging Setpoints

The ITC's battery charger factory setpoints are for wet batteries. Do not use GEL type batteries without changing the factory setpoints via the configuration switches.

CAUTION

Do not operate DC loads, such as DC lights, pumps, etc., during battery charging. The loads may cause overcharging by preventing the charging stages from reaching their 'trigger points' or may cause the battery to run down even though the charger is ON.

T 1 Figure 2.2-2 Battery Charger Factory Setpoints

	Guideline	SP00172 24V	Factory Setpoint (for Wet Battery)		Factory setpoint for Gel/AGM Battery		Units
			12V	24V	12V	24V	
Bulk Charge Volts		28.6	14.2	28.4	14.1	28.2	VDC
Bulk Charge Current	20% C Rate	60	80	60	80	80	Amps
Absorption Charge Volts		28.6	14.5	29.0	14.2	28.4	VDC
Absorption Charge Current		55	40	55	40	40	Amps
Absorption Maximum Time		10	10	10	10	10	Minutes
Float Charge Volts		26.6	13.2	26.4	13.7	27.4	VDC
Equalize Volts	Wet only	N/A	15.5	31.0	N/A	N/A	VDC
Equalize Maximum Time	Wet only	N/A	15	15	N/A	N/A	Minutes

Battery 'C Rate' is equal to battery Amp Hour capacity.

Battery Temperature Sensor Option

The battery temp sensor is designed to reduce the float voltage when the battery temperature exceeds 25° Celsius. No reduction in float voltage should occur below 25°C (77° F). The battery temp sensor plugs into P7, which is located on the left side of the control board. See F 13 Figure 3-1 Customer Terminations. The battery temperature sensor and 35' cable kit part number is ITC-BTS. Individually, the temperature sensor part number is D012684 and the cable part number is D012638.

Automatic Power Management (APM)

A key feature of the battery charger operation is Automatic Power Management (APM). This feature monitors the AC input current and will reduce the battery charger output as necessary to keep the AC input current under the APM setpoint. The APM circuit will not limit power to the passthrough AC loads. If the passthrough AC loads exceed 30 Amp, the battery charger output will be reduced to zero and the breaker may trip.

GenStart

It should be noted that the Generator Start Operation is designed to minimize the generator run time, so at the present set points there is no Absorption stage per se. Therefore, the batteries must be periodically conditioned by leaving the generator on, or charging them with another system.

The GenStart feature is designed for use in installations where a generator is used to provide AC input power for battery charging. The GenStart feature provides a contact closure to signal the generator to start when battery voltage falls below the 'Generator Start Volts' 11.0 (22) VDC setpoint. The GenStart contacts open when bulk charging current fall below the 'Generator End Amps' 20 Amp DC setpoint. The Bulk charging current is checked every 4 minutes, therefore the minimum generator ON time is 4 minutes. The contacts are NEC Class 2, rated 2 amps at 24 VDC.

It should be noted that the GenStart contacts are shown in Figure 1.4-9 Customer Terminations, and likewise a similar set of Normally Open Contacts are available to indicate a "Low Battery" or "Fan On" condition.

Caution

The battery charging process will be affected if 12 (24) VDC loads are being powered during battery charging. The increased charger output, required to power those loads, may keep the charger from reaching the 'Generator End Amps' setpoint.

Charger and APM Programming

The chart below shows the control switch settings for programming the ITC Charger and APM settings.

NOTE: It should be noted that the power switch on the front of the unit must be cycled to read in the new Control Switch settings into memory. The new values will not be recognized until this takes place.

The first 4 (1-4) switches program in the Maximum Charger Current and the next 4 (5-8) program in the APM Current Limit.

The next switch (switch 9) is for selecting either Wet or Gel type batteries.

The next switch (switch 10) is reserved for future expansion.

The next switch (switch 11) is reserved for future expansion.

The next switch (switch 12) is reserved for selecting a Master/Slave remote with multiple Control/Display Units.

Note: The figure below is also available on the Rear of the Control/Display Unit.

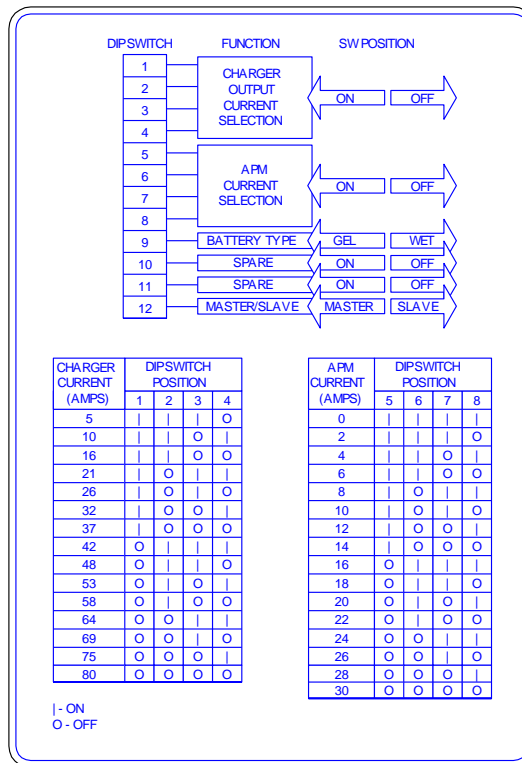

Note: After a new switch setting is set, the power switch must be cycled on the main unit for the new setting to take effect.

F 12 Figure 2.4-1 APM/Charger/Config DIP Switch Settings

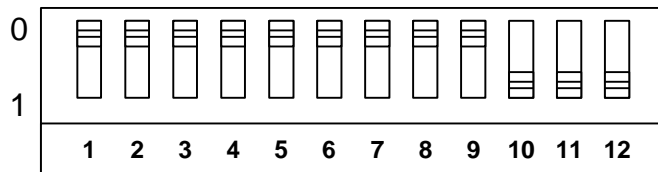

The graphic to the left indicates the factory defaults. Switches 1 through 4 show a maximum charger current setting. Switches 5 through 8 indicate 30-amp automatic power management. Switch 9 has selected Wet Cell battery configuration. Switch number 12 indicates "Master" display/control unit.

F 13 Figure 3-1 Customer Terminations

All field wiring enters the ITC housing through the side panels.

Customer Wiring Identification

REMOTE MASTER AND SLAVE CONNECTORS

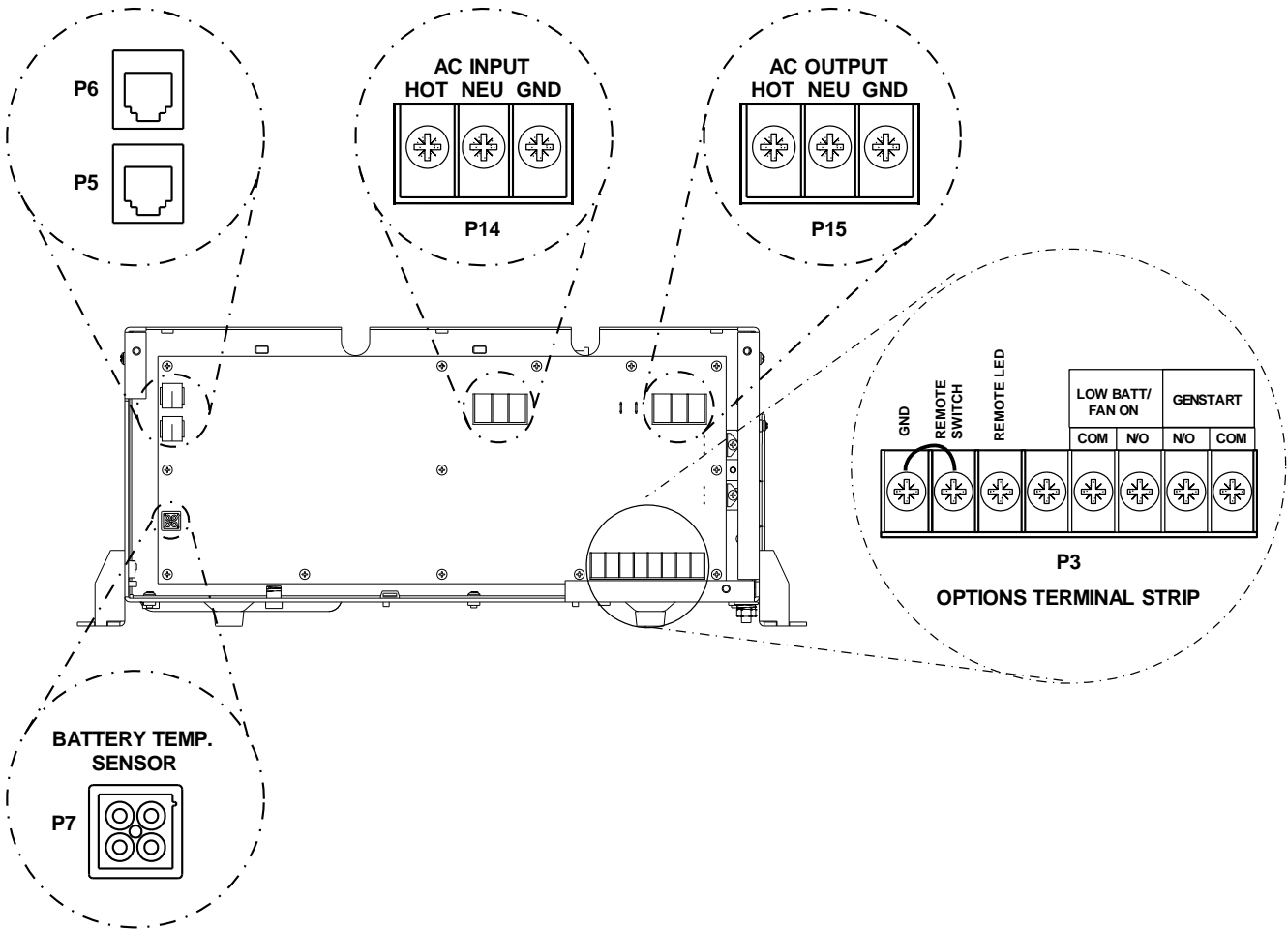

AC Input & Output Wiring

The AC wiring compartment is located on the front right side of the unit. A removable access cover covers this compartment. Two cable clamps are installed for the AC input and AC output wiring. The removable access cover can be removed by simply removing the screws on the front panel of the unit (ONLY!). There is no need to remove screws from the top or sides of the unit to gain access to the AC wiring compartment. Inside the compartment is a terminal strip for making AC input and AC output connections (**P14** and **P15**).

NOTE

The AC output voltage and the *required* AC input voltage of the ITC is 120 VAC, 60Hz.

DC (Battery) Wiring

A DC wiring compartment is located behind the wiring panel on the right side of the unit. The compartment contains a removable access cover on the top of the inverter and two cable clamps for the battery positive and battery negative cables. The inverter's battery cable terminal studs are 5/16-18 and can accommodate Cable sizes up to 250 MCM.

Front Panel Control/Display Outlet

This is a RJ-11 (6-Wire) jack (P5) for communications with the Control/Display Unit. A secondary

Control/Display unit can be plugged into the P6 jack who would be configured as a *slave*.

System ON/OFF Switch

Use this rocker switch to turn the system ON and OFF and to reset the system. This switch is located on the front panel of the system. If placed in the "OFF" position, this switch will override the operation of a remote ON/OFF switch connected to terminals 7 and 8 of the Options connector shown in Figure 3-1 – Customer Terminations.

WARNING: The System ON/OFF Switch does not interrupt the DC input power to the system, so it must be noted that dangerous DC voltages still exist inside the unit, even if the power switch is turned off.

Remote Signal Contacts

Terminal Contacts provide capabilities for Remote Inverter Power ON/OFF and Power indication, Remote Low Battery Warning or Fan On indication, and GenStart control. Contacts are rated 2 amps at 24 volts, Class 2 circuits. Wiring connections are made through an 8 position Options terminal block. Screw pressure-clamp terminals accept up to 14-gauge wire.

A remote power switch will control the system by tying terminals 7 and 8 of the options connector (shown in Figure 3-1) together. This will actuate an internal relay that turns the control power on. The Power On/Off switch on the front panel defeats this remote switch.

In addition, a terminal for a remote LED indicator is provided (terminal 6) with a current limiting resistor integral to the circuit.

INSTALLATION

Unpacking the Inverter

Inspect the shipping container and equipment for loose or damaged parts. If any damage is found, immediately notify the freight carrier.

Basic Guidelines

The wiring of your inverter installation should conform to the National Electric Code (NEC) and any other state or local codes in effect at the time of installation. These codes have been written for your protection and their requirements should be followed.

Mounting

Locate a secure, dry, flat horizontal surface large enough to mount the inverter. The location should be as close to the battery as possible without being in the same compartment and should provide adequate ventilation to maintain room temperature while the inverter is operating. The location must allow unobstructed cooling airflow at sides, rear, and bottom of the unit, and the location must be free from road spray, dripping water or other moisture contamination. A recommended minimum clearance of 4 inches (102 mm) should be maintained on all sides of the unit.

WARNING: Risk of fire or explosion. The inverter must not be mounted in fuel storage areas, battery compartments, or other hazardous areas where potentially explosive gases may be present.

WARNING: It is important to utilize the included mounting brackets mounting. Mount the inverter in the under cabinet method or bolted to a shelf. There **must be a minimum of 5/8 inches below the unit**, which provides adequate airflow to cool the Inverter/Charger. If the unit is to be set on its base (in a shelf mount configuration) and not bolted down, make certain that the mounting feet are bolted to the unit to provide the adequate clearance as shown below.

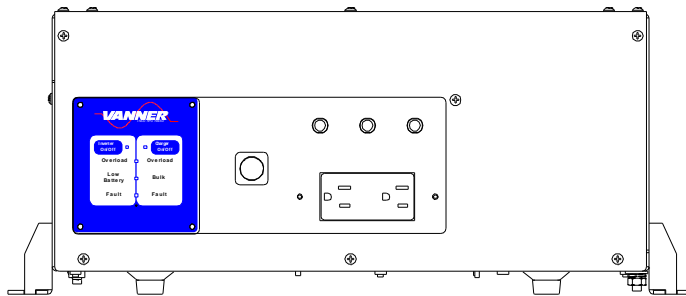

F 14 Figure 4.1-1 Shelf Mount Configuration

NOTE

The wiring of your inverter installation should conform to the National Electric Code (NEC) and any other state or local codes in effect at the time of installation. Article 551 of the NEC requires any DC cable from a battery, which measures longer than 18 inches along its length, be protected by a fuse. Other codes may require each ungrounded output conductor from a storage battery, other than to the engine cranking motor, to have a manually reset trip-free circuit breaker or fuse within 18 inches of the battery as measured along the conductor.

DC Wiring

Preliminary Considerations

1. **BE AWARE** that, as a large number of capacitors become charged upon completion of the DC circuit, **THERE WILL BE A LARGE SPARK** when the last battery connection is made. The spark is normal and will occur every time the batteries are connected.
2. The DC cables should be as short as possible. It is electrically more efficient to run the lower current AC wiring longer distances than the DC cables. (See DC Cable Sizing Chart for proper size.)
3. Route the DC positive and negative cables as close together as possible, and use cable ties to keep them together. This reduces some electromagnetic radiation that could interfere with some sensitive electronics.
3. On vehicle installations do not use the vehicle chassis as the DC negative conductor. Use a cable the same size as the DC positive to go directly from the inverter to the battery negative.
4. Route the AC and DC power wiring separately, and with as much physical separation as possible, from low voltage wiring such as audio and video signal wires.
5. DC power input cables that pass through steel or other ferrous metal walls need to pass through the same hole. If two holes are required, cut a slot connecting the two holes to prevent a transformer effect.
6. Do not allow wire fragments or metal shavings to fall into the DC wiring compartment or to enter the inverter in any way. Severe inverter damage will result which is not covered by the warranty.
7. Do not connect the inverter to the battery at this time. Final battery connections will be made after all installation issues have been inspected.
8. **WARNING:** A poorly made high current connection may result in the risk of fire and personal injury.
9. **WARNING:** Be sure of the polarity of the DC input wiring. Reverse polarity may severely damage your inverter and is not covered under warranty. Risk of fire or explosion of batteries may occur due to very high currents.
10. A DC fuse is required to properly protect the inverter.
11. The table below shows the recommended minimum cable size which should be used. Wire sizing charts published in the NEC may allow a greater amp capacity than we recommend. We have sized the cable for a minimum voltage drop on the cable to maintain better performance of your inverter installation. The inverter's DC cable terminal lugs can accommodate cable sizes up to 250 MCM.

T 2 Table 4-1 DC Cable and Fuse Sizing Chart

DC Cable Size	Max. Distance from Inverter to Battery in Feet	Terminal Lug - Amp Part Number	Terminal Crimping Tool – Amp Part Number
	ITC12-2100W/ ITC24-3600W (ITC12-3200W)		
250MCM Copper Conductor	24 (16)	325703	AMP DYNA-CRIMP Head - Part #69099 AMP DYNA-CRIMP Die - Part #46751-2 AMP DYNA-CRIMP Hydraulic Power Units - Part #69120-1 or 314979-1
4/0 Copper Conductor	20 (13)	321271	AMP Rota-Crimp Part# 600850 (2/0-4/0)
Fuse Information	Bussman Part Number	Vanner Part Number	
ITC12-2100	Bussman ANL300	03645	
ITC12-3200	Bussman ANL500	03646	
ITC24-3600	Bussman ANL300	03645	
SP00172	Bussman ANL300	03645	
Fuse Holder	Bussman 4164	03637	

DC Wiring Installation

The DC input terminals are located in the rear right side of the unit and accessed from the top. The connections are 5/16-18 brass studs that require a lugged connection and are to be tightened by a torque wrench. The positive and negative cables enter the compartment through separate strain reliefs located at the right front of the unit.

WARNING

Never make electrical connections "live". Make the connections to the inverter first, and the battery, last. Make certain the ON/OFF control switch on front of inverter is in the OFF position before connecting to the battery.

NOTE

Severe damage to the inverter will result, which is not covered under warranty, if wire fragments or other metal particles enter the inverter through the DC wiring compartment.

Procedure

- Step 1: Turn the inverter OFF and disconnect all AC and DC power to the wiring harness. Make sure power to the inverter wiring is disconnected. Verify that the inverter is turned OFF (the Inverter ON-OFF switch is in the OFF position).
- Step 2: Select a location for the unit. An ideal installation location has the following characteristics:
- Close to the battery without being in the battery compartment (usually within six feet).
 - Protected from the weather.
 - Well ventilated.
- Step 3: Connect the DC cables to the inverter:
- A) Remove the cover plate on the DC cable compartment exposing the positive and negative threaded studs.
 - B) Remove the two flat washers, split ring washers, and nuts from the threaded studs.

- C) Put lugs (For the appropriate wire size called out in Table 4-1) on the ends of the Positive and Negative DC Cable ends with the appropriate terminals. Be sure that all cable strands are completely in the lug to avoid shorting to another conductor.
- D) Insert the black, negative (-) cable end through the strain relief and onto the negative terminal threaded stud, and tighten to 275 inch-pounds. .
- E) Insert the red, positive (+) cable end through the strain relief and onto the positive threaded stud, and tighten to 275 inch-pounds.
- F) Tighten the two cable clamps.
- G) Inspect the DC cable compartment to ensure that no foreign particles are present.
- H) Replace the cover plate over the DC cable compartment.
- I) Repeat steps A, D, E, and H every 30 days.

- Step 4: Route DC input cables. Route the negative and positive DC input cables from the inverter to the battery. If required, protect cables where they contact hard, sharp edges.
- Step 5: Install the in-line fuse. Install the in-line fuse in the red, positive DC input cable between the battery and inverter, within 18 in. of the battery or DC wiring bus system.
- Step 6: Once all cables are double checked for proper connection and polarity, connect the battery to the appropriate cable.
- Step 6: Verify Installation. Verify all connections are tight and the cables are secure.

AC Wiring

Preliminary Considerations

1. Output and Input Voltages
The ITC is designed to operate with an AC Output Voltage and AC Input Voltage of 120 VAC, 60Hz.
2. AC Wire Size
To properly size the AC input and output wiring the installer must consider the inverter output capability, the inverter passthrough capability, and the battery charger input requirement. The AC input/output terminal strip is a compression lug style that will accept up to 10 AWG copper wire.
Model ITC12-3200 – The 26.7 amp at 120-volt (3200-watt) inverter output capability requires #10 AWG wire minimum is used for the AC output. The AC transfer switch is rated 30 amps at 120 volts.
Use input copper wire up to 10 AWG to suit the AC input source. The AC output wire should be the same size as the AC input wire but not less than #10 AWG.
3. The AC Input and output wiring compartment is accessed by removing the front panel and is on the right side of the unit. Field wires are brought in through two cable clamps to the terminal strips identifying the “AC Input” and “AC Output” terminals.
4. **If AC Input is wired into the AC Output, damage will occur to the inverter!** The power distribution circuits must be designed to prevent AC power from an external source (shore power or a generator) from feeding back into the inverter's AC output.
5. The inverter AC output must be wired to a Ground Fault Circuit Interrupter (GFCI) to ensure a safe installation. Always maintain an isolated neutral downstream from the GFCI to prevent nuisance tripping.
6. The Circuit Breakers on the front panel are NOT BRANCH RATED! In all installations please follow all national and regional electric codes and use the mandated branch rated breakers for power distribution.
7. The CHASSIS BONDING LUG located on the right of the unit has been provided for safety to prevent possible shock hazards. Connect a #8 AWG minimum wire to this terminal and then to chassis of the vehicle, the installation's grounding system, or to earth ground.
Failure to connect the chassis bonding lug to the chassis of the vehicle, the installation's grounding system, or to earth ground may result in a lethal shock hazard.

AC Wiring Procedure (refer to Figure 3-1)

Warning: Make certain that the AC field wiring (upper right of the wiring compartment) and the Signal wiring (at the lower right of the wiring compartment) are kept separate to avoid any problems or conflicts

with code. Make certain to route the Signal wires out of the provided port (lower most on the right side of the unit). This is to insure that there are no problems that may arise from the poor insulation properties of most signal level wire. Make certain that the auxiliary contact and option wiring are routed below the barrier, and the AC Power Wires above the barrier.

Step 1: Connect the AC output. Remove the front cover to expose the AC input and output terminal strips. Identify the right terminals labeled "AC Output". Insert the output field wires through the nearest (to the board) strain relief into the AC wiring compartment. Tighten the strain relief. Connect the copper field wires to the proper AC output terminals and tighten to 9 lb-in max.

Warning: Do not attempt to use a stranded wire. Stranded wire has a tendency to break off some of the strands and will drop into the unit causing possible failures. If a stranded wire is used, the appropriate "ring terminal" must be used.

Step 2: Connect AC Input. Identify the terminal strip's terminals labeled "AC Input". Insert the field wires through the (closest to the front panel) strain relief into the AC wiring compartment. Tighten the strain relief. Connect the copper field wires to the proper AC input terminals and tighten to 9 lb-in max. Replace the front cover.

Warning: Do not attempt to use a stranded wire. Stranded wire has a tendency to break off some of the strands and will drop into the inverter causing possible failures. If a stranded wire is used, the appropriate "ring terminal" must be used.

Step 3: Connect Bonding Lug. Use a 8 AWG or larger copper conductor to connect the chassis bonding lug to the chassis of the vehicle, the installation's grounding system, or to earth ground.

Step 4: Verify Installation. Verify all connections are tight and secure for maximum performance.

System Start-up and Testing

Step 1: Completely install the ITC-Series Inverter/Charger following the system design considerations and instructions provided previously in this manual.

Step 2: Place the System Power On/Off switch located on the front of the inverter in the OFF position.

Step 3: Verify that the external GFCI breaker is reset and connect an AC load, such as a 100-Watt light. Note: some GFCI's require power to be applied before they will reset.

Step 4: Turn ON the battery DC power to the inverter.

Step 5: Turn ON the AC shore power (or generator) to supply the AC input power to the system

Step 6: Place the System On/Off Power switch located on the front of the inverter to the ON position.

Step 7: The Lights on the Control/Display Unit on the front of the inverter should come ON, by doing a lamp test.

Step 8: Disable the Charger Operation of the unit by pressing the Charger ON/OFF button once if the Charger LIGHT is On or blinking. This turns the charger function OFF.

Step 9 If the Inverter LIGHT is not On or blinking, enable the Inverter Operation of the unit by pressing the Inverter ON/OFF button once. This turns the Inverter function ON.

Step 10 The AC output test light should come ON, indicating the presence of shore power and correct operation of the AC transfer switch.

Step 11: Turn off the AC shore power input. The AC output test light should immediately quickly blink once, indicating the transfer switch transferred the test light from shore power to inverter power.

Step 12: At this point, apply AC loads up to rated output watts to verify full-power operation.

Step 13: Apply shore power. After a delay the AC output test light should blink and the ITC Inverter LIGHT should blink indicating the transfer of the load from inverter power to shore power.

Step 14: Test the battery charger operation

- A) With shore power applied, press the Charger ON/OFF button to enable the Charger (if not enabled). The Charge LIGHT should come on and the batteries should begin charging. Remember to reduce the loads on the unit since the APM will limit the available power to the charger based on its settings.
- B) Disconnect the shore power – the unit should transfer back to Inverter mode.
- C) Discharge the battery by placing the AC load on the system and operating the inverter.
- D) When the battery charge level is low, the inverter will turn off.
- E) Connect an ammeter to the DC cables between the inverter and the battery to monitor the current (DC amps), and a voltmeter to the battery to monitor the battery voltage. The battery charger will step through its sequence and stop in the float mode.

Step 15: The system is now ready for operation.

Battery Temperature Sensor

Route battery temperature sensor (BTS) cable from inverter to the battery. Note: the keyed BTS cable has same connector on both ends so cable connector orientation does not matter. Make sure cable does not come into contact with sharp edges and is secured with nylon ties or equivalent. Plug the BTS cable into P7 on inverter/charger control board. See F 13 Figure 3-1 Customer Terminations. Plug opposite end of BTS cable into the battery temperature sensor, which is attached to battery with double-sided tape.

GENERAL INFORMATION SECTION

Generic Inverter Description

In general, an inverter converts DC electrical power into AC power. This power can be used to operate various AC-driven appliances. Typical DC power sources include batteries that store electrical energy, power generated from a vehicle alternator or renewable energy sources such as photovoltaic (solar) panels both with the appropriate regulator or charge controller to bring the DC source within the operating range of the inverter.

The most common battery systems are 12 or 24 volt. Some systems, however, operate on higher voltages such as 32, 36, 48, or 120 volts. The most common inverter AC output power is 120 volts at a frequency of 60 Hz. Some inverters, however, are designed to produce 240 volts, or both 120 and 240 volts at 60 Hz. Because some countries use power of different voltage and frequency (e.g., 230 volts at 50 Hz), inverters are available to conform to these requirements.

The three available inverter types are distinguished by the type of AC output waveform they produce. This waveform affects the AC loads they operate. This section provides an overview of these inverter types, including the advantages and disadvantages associated with using each type.

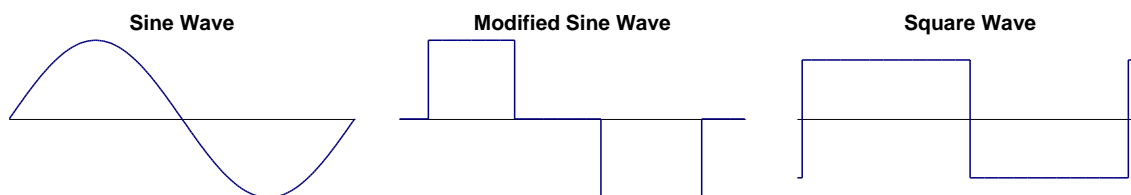

Sine Wave Inverter

Sine wave inverters produce an AC output waveform like power produced by the electric utility companies and rotating generators. The sine wave inverter's waveform is characterized by the highest peak voltage and smooth voltage transitions (no square wave components). Such inverters are the most costly of the three inverter types because they contain additional electronics to produce the required waveform. A measure of the sine wave quality is *Total Harmonic Distortion* (THD), and is expressed in a percentage. The lower the THD the higher the quality of the sine wave power.

Modified Sine Wave Inverter

Modified sine wave inverters are sometimes called “quasi sine wave inverters” or “modified square wave inverters.” Modified sine wave inverters generally cost more than square wave inverters because they contain additional electronic circuitry to produce true RMS regulated AC output. Modified sine wave inverters have higher AC peak voltages than square wave inverters, and automatically control the width of the AC output waveform to regulate the output voltage (pulse-width modulation). The shape of the modified sine wave inverter’s waveform includes a square wave component. It is stepped in such a way, however, to closely approximate the true sine wave produced by the electric utility companies. Although this waveform has a higher peak voltage than do square wave inverters, its peak voltage is not as high as a pure sine wave. Therefore, AC loads containing power supplies might not always operate properly on the modified sine wave inverter.

Square Wave Inverter

The square wave inverter is a low cost device that produces a pure square wave AC power output. This AC power can be an accurate 60 Hz frequency if it is crystal controlled. It does not have the necessary peak voltage to properly operate many AC appliances that contain electronic power supplies (e.g., computers, TVs, and VCRs). The square wave is appropriate when operating AC loads such as resistive heating devices.

Inverter Sizing

Output Power Rating - Power output is an important consideration when purchasing an inverter. Power is defined as the rate that a device produces (or uses) electrical energy. This rate is measured in watts or kilowatts (one kilowatt equals 1,000 watts), or sometimes in volt/amps. Volt/amps are roughly equal to watts and are obtained by multiplying volts times current produced or used by a device

To properly determine an inverter size (in watts) for your application decide which AC loads you plan to operate. Inverter size is the sum of the wattages of the AC loads that you wish to run at the same time, plus a safety factor of 10 to 20 percent.

Continuous Output Power - Continuous power is defined as the AC power in watts (or volt/amps) that an inverter can produce on a continuous basis at a given temperature.

Surge Output Power - Inverter power can also be rated in terms of surge power. Surge power is the short term duration of AC power that the inverter can produce. It is often specified as the watts (or volt/amps) that can operate a resistive load for two or three seconds. Sometimes this is specified in AC amps because the inverter may allow output voltage to drop (which would reduce wattage). Like continuous power, the surge rating is affected by ambient temperature.

Note - Regardless of an inverter’s power ratings, an inverter’s AC output capability is only as strong as the DC source. To achieve optimum performance, an inverter must be installed with properly sized cable and have an ample DC supply. Recommended cable sizes are listed in the DC Cable and Fuse Chart (Section 4.2). The following sections in this manual will cover the basic information required to properly size the inverter battery and the vehicle alternator. Keep in mind that if information in this manual directly conflicts with instructions from a specific battery or other equipment manufacturer, Vanner recommends that the other manufacturer’s recommendations be followed.

DC Power Consumption

An inverter takes in DC power, and produces AC power to operate AC loads. In general, we can see a direct relationship between DC input power and AC output power. This allows us to establish the following rule of thumb:

For 12 volt DC inverters: Output Watts ÷ 10 = DC Input Amps.

For 24 volt DC inverters: Output Watts ÷ 5 = DC Input Amps.

This rule of thumb can be used to estimate the minimum alternator size required for your application. It may also be used in calculating the minimum size battery required when operating from an alternator and battery combination; a photovoltaic panel and battery combination; or when operating from battery alone. The following examples should help to clarify the use of this rule of thumb.

Example

What is the DC current draw of a 12-volt DC input inverter when it is operating a vacuum cleaner with a nameplate rating of 6 amps at 120 volts AC?

The appliance rating is given in amperes, so we must first calculate the power it consumes. Then the rule of thumb can be used to find the DC input current of the inverter.

Output power = 120 volts x 6 amps = 720 watts, and
DC input current = $720 \div 10 = 72$ amps DC.

This information to estimate the DC input current requirement for an inverter will allow you to size an alternator or charging system to supply an inverter for continuous operation. This rule of thumb will be used later in the discussions on battery sizing.

Battery Terminology and Ratings

Batteries used for automotive applications generally are lead-acid storage batteries. They can be separated into two categories according to their use: engine cranking batteries and deep cycle batteries. The engine cranking battery is specifically designed to supply hundreds of amps for a short period of time to start an engine. Cranking an engine usually uses a small portion of the battery's total capacity and once the engine is running, the engine's alternator quickly recharges the battery. The deep cycle battery is specifically designed to deliver current for extended periods of time and can be almost totally discharged before recharging.

The "deep cycle" lead-acid battery is designed to withstand the deep discharge/recharge cycling that is typical of most inverter installations. These batteries are available in the "maintenance free" style where the electrolyte does not need to be checked or replenished and they also are available in the gelled electrolyte style or "Gel Cells". Deep cycle batteries are generally advertised for use in recreational vehicles or boats and are sometimes referred to as RV or marine batteries.

Battery Council International (BCI) is a voluntary industry organization that has helped to standardize battery ratings. Ratings in use at this date are:

CCA (Cold Cranking Amperes): Rating in amps a battery cold soaked at 0°F or -20°F will carry for 30 seconds and maintain a minimum terminal voltage of 7.2.

MCA (Marine Cranking Amperes): Rating in amps a battery cold soaked at 30°F will carry for 30 seconds and maintain a minimum terminal voltage of 7.2.

RC (Reserve Capacity): Rating in minutes a battery will carry a 25-amp load at 80°F and maintain a minimum terminal voltage of 10.5.

AH (Amp Hour): At the "20 Hour Rate", also called the C Rate, a battery having a 100 AH rating must carry a 5 amp load for 20 hours ($100\text{AH} \div 20 \text{ hours} = 5 \text{ amps}$) and maintain a terminal voltage of 10.5 at 80°F. (Two 100AH 12volt batteries connected in series provides 100AH at 24 volts. Two 100 AH 12volt batteries connected in parallel provides 200 AH at 12 volts.)

CCA and MCA are used for sizing an engine cranking battery and have no bearing on a battery's cycling ability. RC is a rating given to cranking batteries to provide an idea of how long a vehicle could be driven if the vehicle charging system were to fail.

The most important and probably least understood battery capacity rating is the ampere-hour. One simple reason the AH rating is misunderstood is that a battery rated at 100 AH cannot always deliver 100 AH. The underlying reason is the efficiency with which the battery converts its chemical energy into electric energy. The AH capacity of a battery is affected in the following ways:

Discharge rate: A battery becomes less efficient as the discharge current increases. For example, a typical

100 AH battery is specified to be able to deliver 5 amps for a period of 20 hours. If the discharge current were increased to 25 amps, the capacity will be reduced to approximately 75 AH (25 amps x 3 hours = 75 AH).

Operating temperature: A battery becomes less efficient at lower temperatures. Most battery manufacturers specify the battery AH capacity at 80° F. At a temperature of 32° F, the same battery will have only about 65% of its rated capacity even though it may be fully charged. At a temperature of 0° F, a battery's capacity will be reduced to about 40% of its rated capacity.

Battery age: As a battery is used, the active material on the battery plates will gradually deteriorate and become useless. As the battery gets older, there will be less and less useful material left on the plates and the operating time will become noticeably shorter. A battery will age faster (lose active material from its plates faster) if it is deeply discharged regularly, if it is left in a discharged state for extended periods of time, or if it is repeatedly overcharged.

Series and/or Parallel Connected Batteries: Up to this point we have spoken of the battery as if it were a single battery. In some cases this may be true, but in general, the battery may be made up of several individual batteries electrically connected together to form a "Bank" of batteries. Batteries can be connected in series, parallel, or a combination of series and parallel as long as all of the batteries in the bank are of equal ratings, are from the same manufacturer, and are the same age. Old and new batteries should never be mixed in the same battery bank. Mixed batteries will result in accelerated battery failure due to the unequal discharge and recharge rates.

A series connection is where two or more batteries are connected positive (+) to negative (-). The total voltage of the battery bank is the sum of the voltage of each battery in the bank. For example, most large custom coaches require a 24-volt battery to crank the large diesel engine. The 24 volts is usually provided by connecting two 12 volt batteries in series, and sometimes by connecting four 6 volt batteries in series. The ratings of the series connected battery bank remain the same as the individual battery's rating. If the battery bank is made up of two 8D size batteries in series, each with a CCA of 1050 amps, 425 minutes RC, and amp-hour capacity of 200 AH, then these individual battery ratings are also the ratings of the entire 24 volt battery bank.

Parallel connected batteries are batteries which are connected positive to positive and negative to negative. They form a battery bank that has the same voltage as each individual battery. The ratings of a parallel connected battery bank, in general, are the sum of the individual batteries. For instance, if two 8D batteries are connected in parallel, and each battery has the ratings given in the paragraph above, then the ratings for the battery bank become 2100 CCA, 900 minutes RC, and approximately 400 amp-hours. Parallel connected batteries should be of the same voltage and rating to achieve optimum battery life and performance.

Sizing the Inverter Battery

Sizing a battery system for an inverter application can be a very tedious task if all the different variables, such as discharge rate, depth of discharge, and operating lifetime are included in the calculations. To simplify these calculations and get a reasonably correct battery size, we will assume:

- 1) A 50% depth of discharge for the purpose of obtaining a reasonable life time for a reasonable battery system cost
- 2) There is no charge current into the battery system
- 3) The batteries are in a fully charged state at the beginning of the discharge cycle
- 4) The DC current draw from the battery does not exceed 1/3 the C rate for any length of time.

Follow the steps listed below to find the AH capacity required for your application.

Step 1: Make a list of each appliance, its power requirement in watts, and the amount of time in hours it will be operating between charging cycles. Note: If the appliance is rated in amperes (amps) instead of watts, multiply the amps by the voltage (120 or 240) to get watts.

Step 2: Calculate the watt-hours required for each appliance by multiplying the power requirement by the operating time of that appliance.

- Step 3: Calculate the total watt-hours needed by adding together the watt-hours of each appliance.
- Step 4: Find the amp-hours consumed by dividing the total watt-hours found in step 3 by 10 for 12 volt DC systems or by 20 for 24 volt DC systems.
- Step 5: Multiply the amp-hours consumed by 2 (for 50% depth of discharge) to get the battery amp-hour capacity desired.

Example 1: Follow Steps 1 through 3 (above)

<u>Appliance</u>	<u>Power Rating</u>	<u>Operating Time</u>	<u>Watt-Hours Consumed</u>
TV, VCR, Stereo	225 watts	2.5 hours	563 watt-hours
Small Refrigerator	300	3.8	1,140
Microwave	800	0.3	240
TOTALS			1,943 watt-hours

Step 4: Amp-hours consumed = 1943 watt-hours ÷ 20 = 97.15 amp-hours for 24 a volt system.

Step 5: The minimum battery size for this application is 2 x 97.15 = 194.3 amp-hours.

Battery and Charging System Considerations

The Battery and DC Charging System is a very important part of your inverter installation. The Battery System is responsible for supplying all of the DC power required by the inverter. The system normally consists of the primary charger (engine alternator or photovoltaic array), a secondary charger, if used, the battery, and other equipment which may be used such as battery isolator diodes. The complexity of the system depends on the way the inverter is used. In some cases, such as utility or service vehicles, the system may be as simple as the engine alternator and the cranking battery that also powers the inverter. In most cases, additional equipment is needed to provide additional DC power and/or protection. These systems can be grouped into two categories, the single battery and the dual battery systems.

In the single battery system, there is one battery, which is shared for starting the engine and operating the inverter. This is a common practice in a service vehicle where the engine runs all the time and allows the alternator to provide continuous charging for the battery. In this case, the inverter can be connected directly to the engine cranking battery. The most important detail of this system is the alternator output rating. The continuous output of the alternator must be at least as much as the total DC current draw on the system. The total DC current draw must include the inverter, warning lights, radios, engine controls, and any other device connected to the DC system. Care should be used when operating this type of system while the engine is shut off. The inverter will shut itself OFF for low battery but most other DC loads will not. The vehicle battery may be also drained too low to restart the engine.

The dual battery system uses two separate batteries, one for starting the engine and operating the vehicle's systems, and one for operating the inverter. The two batteries are usually referred to as the "cranking battery" and the "house or auxiliary battery" respectively. The two separate batteries are usually charged from the same source, the engine alternator, but are separated by a device called a battery isolator. The battery isolator allows DC current to flow from the alternator into each battery, but blocks current from flowing from one battery to the other. This is required to protect the cranking battery in recreation vehicles, boats and other vehicles where the inverter needs to be operated when the engine (therefore the alternator) is not running.

Battery Charging Guidelines

CAUTION

The following information on battery charger setup adjustments should be used as guidelines only. Vanner strongly recommends that you contact the manufacturer of your batteries to obtain the specific charging setup values for the type and model of battery you are using. This is because battery charging parameters

such as bulk, absorption, float and equalize voltages vary from one manufacturer to another, and that gel cell batteries have different parameters than wet lead acid batteries. An improperly adjusted battery charger may cause damage to your batteries!

The maximum charging current for a battery is usually equal to 20% of the battery's Amp hour capacity ("C Rating") for lead acid batteries, and 50% of the battery's C for gel cell batteries. The C rate is numerically equal to the amp-hour capacity for the battery. For example, a 280 amp-hour battery has a C rate of 280 amps, and the maximum charge rate would be 56 amps DC. (Note that this is not the same as the battery's Cold Cranking Amp rating.) It is important to also take into consideration that if two batteries are connected in parallel, their amp-hours add, while batteries that are connected in series have the same amp hours as a single battery since they are simply stacked for more voltage. Remember, paralleled = more current; stacked = more voltage.

MAINTENANCE & TROUBLESHOOTING

Preventative Maintenance

There are no user serviceable components inside the ITC-Series Inverter/charger. For service refer to Vanner Incorporated or other qualified service personnel.

Maintenance Items:

For continued reliability and safety, a monthly maintenance program should be implemented to include the following:

1. Check to insure that all AC and DC wiring is secure and connections are tight and corrosion free.
2. Check air ventilation openings for dust and other obstructions.
3. Examine receptacle, indicators and switches for cracks and breaks in insulation material.

Trouble Shooting:

The Unit does not come on when Shore Power or DC is applied and the front Power Switch is on.

Suggestion:

Make certain that the remote switch connected to Options Terminal Strip P3 -terminals (Remote Power Switch P3-7– To Ground P3-8) is functioning properly. If the switch is not installed, make certain that a jumper is present between the two left most terminals (GND and Remote Switch) as shown below.

F 15 Figure 6.1-1 Options Terminal Strip

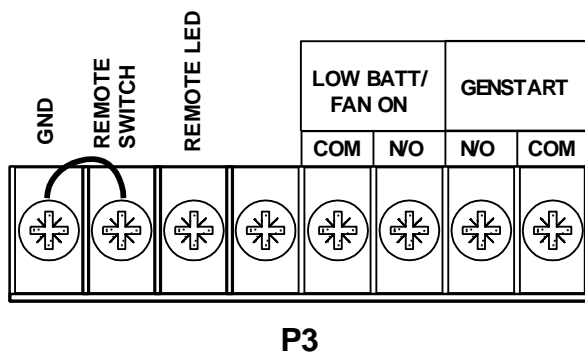

**Vanner Incorporated
4282 Reynolds Drive
Hilliard, Ohio 43026**

**1-800-AC POWER
(1-800-227-6937)
Tel: 614-771-2718
Fax: 614-771-4904**

**www.vanner.com
e-mail: pwrsales@vanner.com**

Manual Number D911149-C

**Printed in USA
Copyright 2005**