

# ***IQ SERIES***

## ***Industrial Quasi Sine Wave AC Power Inverter***



### **Models**

<b>IQ12-2600</b>	<b>IQ12-3600</b>	
<b>IQC12-2600</b>	<b>IQC12-3600</b>	<b>IQC24-3600</b>

Owners Manual

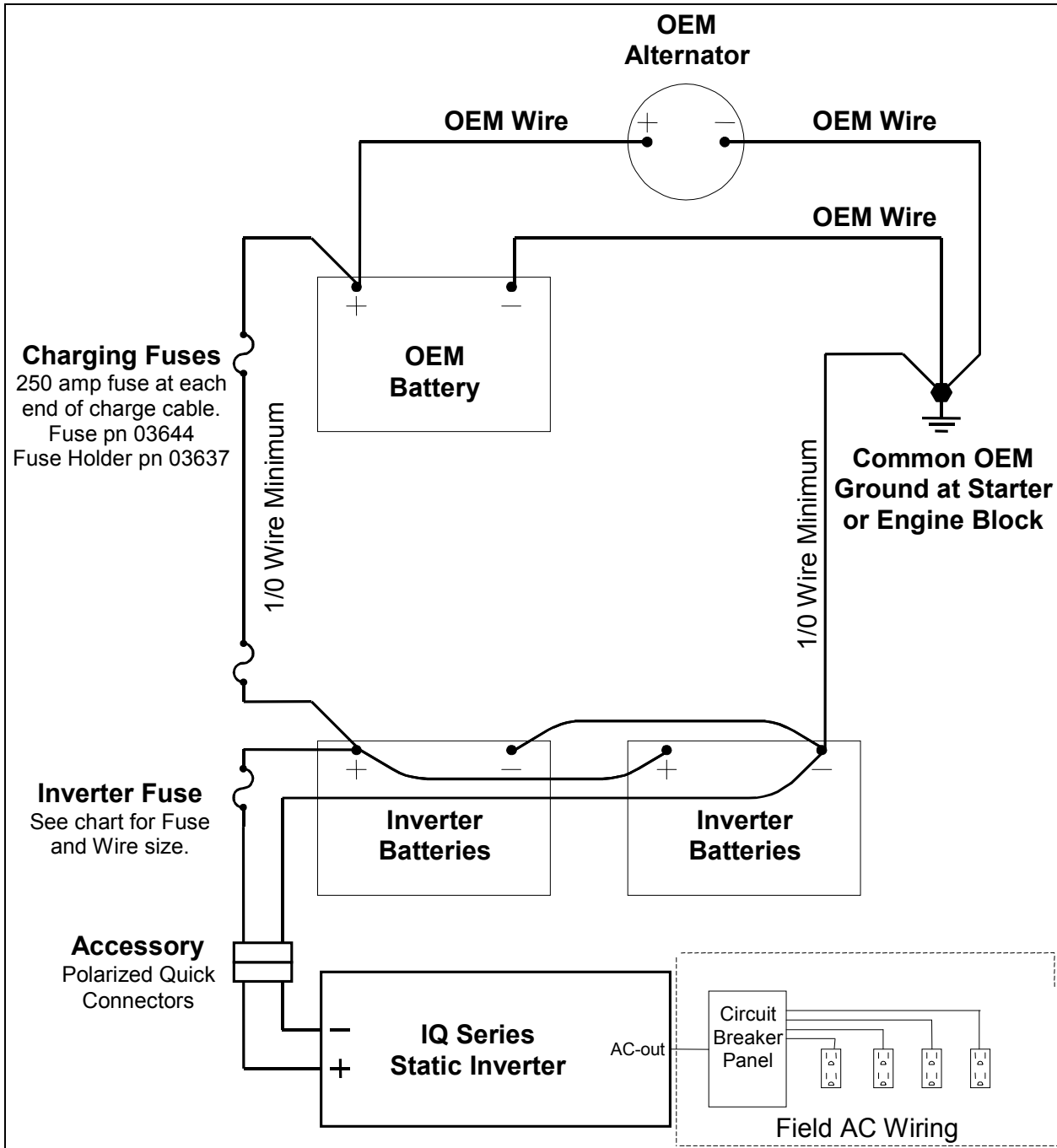

TABLE OF CONTENTS

<b>1</b>	<b>INTRODUCTION .....</b>	<b>5</b>
1.1	MODEL LISTING .....	5
1.2	SPECIFICATIONS                      FIGURE 1 SPECIFICATIONS .....	6
1.3	STANDARD FEATURES .....	7
<b>1.3.1</b>	<b><i>IQ Series Standard Features</i></b> .....	7
<b>1.3.2</b>	<b><i>Additional Features on inverter models (example: IQ12-2600)</i></b> .....	7
<b>1.3.3</b>	<b><i>Additional Features on “inverter/charger” models (example: IQC12-2600)</i></b> .....	7
1.4	ACCESSORIES .....	8
1.5	DEFINITIONS .....	10
<b>1.5.1</b>	<b><i>Quasi Sine Wave:</i></b> .....	10
<b>1.5.2</b>	<b><i>Load Demand Feature and Load Demand Mode:</i></b> .....	10
<b>1.5.3</b>	<b><i>Automatic Transfer Switch:</i></b> .....	10
<b>1.5.4</b>	<b><i>Automatic Power Management:</i></b> .....	10
<b>1.5.5</b>	<b><i>Ambulance Mode:</i></b> .....	10
1.6	IMPORTANT SAFETY INSTRUCTIONS .....	11
1.7	GENERAL PRECAUTIONS .....	11
1.8	EXPLOSIVE GAS PRECAUTIONS .....	12
1.9	PRECAUTIONS WHEN WORKING WITH BATTERIES .....	12
<b>2</b>	<b>COMPONENT IDENTIFICATION AND DESCRIPTION OF OPERATION .....</b>	<b>13</b>
2.1	(1) INVERTER INDICATOR LIGHT .....	14
2.2	(2) ON/OFF SWITCH .....	14
2.3	(3) BATTERY LOW INDICATOR LIGHT .....	15
2.4	(4) OVER TEMPERATURE INDICATOR LIGHT .....	15
2.5	(5) OVERLOAD INDICATOR LIGHT .....	15
2.6	(6) BULK CHARGE INDICATOR LIGHT .....	15
2.7	(7) FLOAT CHARGE INDICATOR LIGHT .....	16
2.8	(8) AC CIRCUIT BREAKER .....	16
2.9	(9) AC CIRCUIT BREAKER .....	16
2.10	(10) AC CIRCUIT BREAKER .....	16
2.11	(11) AC OUTPUT RECEPTACLE .....	16
2.12	(12) FRONT COVER .....	16
2.13	(13) AUTOMATIC POWER TRANSFER SWITCH .....	17
2.14	(14) AUTOMATIC THROTTLE CONTROL TERMINAL J31 .....	17
2.15	(15) REMOTE CONTROL JACK J9 .....	17
2.16	(16) BATTERY TEMPERATURE COMPENSATION CONTROL JACK J1 .....	17
2.17	(17) AUTOMATIC POWER MANAGEMENT (APM) PANEL JACK J8 .....	17
2.18	(18) PROGRAMMING CONTROL SWITCHES .....	18
2.19	(19) 120 VOLT AC WIRING .....	19
2.20	(20) DC INPUT WIRING COMPARTMENT .....	20
2.21	(21) GROUND WIRING LUG .....	20
2.22	(22) MOUNTING BRACKETS .....	21
2.23	(23) COOLING FAN .....	21
<b>3</b>	<b>INSTALLATION .....</b>	<b>21</b>
3.1	UNPACKING THE INVERTER .....	21
3.2	INVERTER INSTALLATION CONSIDERATIONS .....	21
3.3	DC WIRING CONSIDERATIONS .....	21

3.4 DC WIRING INSTALLATION PROCEDURE .....23

3.5 AC WIRING INSTALLATION PROCEDURE .....24

3.6 REMOTE MONITOR AND CONTROL PANEL INSTALLATION .....24

3.7 REMOTE AUTOMATIC POWER MANAGEMENT (APM) PANEL INSTALLATION .....25

**4 SYSTEM START-UP AND TESTING PROCEDURES .....25**

4.1 INVERTER START-UP AND TESTING .....25

4.2 PROCEDURE TO CHECK BATTERY CHARGER OPERATION .....28

**5 THEORY OF OPERATION .....28**

5.1 BATTERY CHARGER POWER CONSUMPTION .....28

5.2 BATTERY CHARGER OPERATION .....29

5.3 AUTOMATIC POWER TRANSFER SWITCH THEORY OF OPERATION .....30

5.4 AUTOMATIC POWER MANAGEMENT (APM) THEORY OF OPERATION .....32

5.5 AUTOMATIC THROTTLE CONTROL TERMINAL J31 THEORY OF OPERATION .....32

5.6 AMBULANCE MODE AND STANDARD MODE THEORY OF OPERATION .....33

**6 PREVENTIVE MAINTENANCE.....34**

6.1 MAINTENANCE ITEMS.....34

6.2 TROUBLESHOOTING PROCEDURES .....34

6.3 GFCI TEST RECORD .....36

**7 APPENDICES.....37**

7.1 INVERTER OVERVIEW .....37

7.2 PROBLEM LOADS .....37

7.3 BATTERY TYPES AND RATINGS .....38

7.4 INVERTER SIZING.....39

7.5 DC POWER CONSUMPTION .....39

7.6 OVERALL SYSTEM DESIGN CONSIDERATIONS .....39

**8 NORTH AMERICAN WARRANTY.....43**

LIST of FIGURES

1.2 SPECIFICATIONS                      FIGURE 1 SPECIFICATIONS..... 6

FIGURE 2 IQ SERIES ILLUSTRATION .....13

FIGURE 3 PROGRAMMING SWITCH INSTRUCTION LABEL.....18

FIGURE 4 DC CABLE AND FUSE SIZING CHART.....23

FIGURE 5 BATTERY CHARGING GRAPH.....30

FIGURE 6 AC POWER TRANSFER SWITCH .....31

# 1 INTRODUCTION

Thank you for purchasing a Vanner Power Group IQ Series Inverter or Inverter/Charger. We are confident that you will be satisfied with its performance and its many features. With proper installation and care, you can look forward to years of service from this high performance product.

IQ stands for Industrial Quasi-sine wave.

The IQ Series is a family of dependable inverters (IQ models) and inverter/chargers (IQC models) designed to meet the severe service requirements of the industrial market. All models of the IQ Series produce quasi-sine wave AC output power.

This document will describe the operation, technical specifications and installation procedures of the various models and accessories offered in this product family. We suggest that you familiarize yourself with the model numbers of the inverter and optional accessories you have purchased before proceeding with this manual. If you require additional information please contact your dealer, or contact Vanner at 800-227-6937 (800-AC Power) or 614-771-2718.

**WARNING: Before you install and use your IQ Series Inverter or Inverter/Charger be sure to read and save these safety instructions.**

## 1.1 Model Listing

The IQ Series product line is designed to meet the requirements of a variety of applications. In order to meet these requirements we offer the following models:

<b>Inverter only models</b>	<b>IQ12-2600</b>	<b>IQ12-3600</b>	
<b>Inverter/Charger</b>	<b>IQC12-2600</b>	<b>IQC12-3600</b>	<b>IQC24-3600</b>

**PLEASE NOTE YOUR MODEL AND SERIAL NUMBER HERE FOR FUTURE REFERENCE**

Model Number \_\_\_\_\_ Serial Number \_\_\_\_\_ Date of Installation \_\_\_\_\_

1.2 Specifications

Figure 1 Specifications

SPECIFICATIONS	Model Numbers		
	IQ12-2600	IQ12-3600	
	IQC12-2600	IQC12-3600	IQC24-3600
<b>AC Output Power</b>			
Continuous	2600 Watts	3600 Watts	3600 Watts
Surge (3 sec ) amps	65 Amps	80 Amps	80 Amps
Output Voltage - All Models	120 Volts +/- 5%		
Output Frequency - All Models	60 Hz +/- 0.1 Hz		
Output Waveform - All Models	Modified Sine Wave		
<b>DC Input Voltage Range</b>	10.5 - 16.0 VDC		21.0 - 32.0 VDC
<b>DC Input Current at no load</b>			
Inverter OFF	60 ma		60 ma
Inverter ON in Load Demand Mode	160 ma		160 ma
Inverter ON - Load Demand OFF	1.8 amps		
<b>AC Output Wiring Method</b>			
All IQ Models (inverter only) All circuits are breaker protected	1 GFCI Duplex Receptacle 1 - 15 amp output terminal 1 - 20 amp output terminal 1 - 30 amp output terminal		
All IQC Models (inverter/charger) All circuits are breaker protected	1 GFCI Duplex Receptacle 1 - 30 amp output terminal		
<b>AC Input Wiring Method</b>			
All IQC Models (inverter/charger) All circuits are breaker protected	1 - 30 amp input terminal for charging and feedthrough 1 - 30 amp input terminal for optional feedthrough only		
<b>Battery Charger (IQC Models)</b>			
Charging Output Current	120 amps	60 amps	
AC Input current	Proportional to 30 amps 120VAC input @ 120 amps 12 volt output		
WET Bulk Charge Voltage	14.4 vdc	28.8 vdc	
WET Float Charge Voltage	13.2 vdc	26.4 vdc	
GEL Bulk Charge Voltage	14.1 vdc	28.2 vdc	
GEL Float Charge Voltage	13.6 vdc	27.2 vdc	
<b>AC Input Voltage Tolerance for Transfer Switch</b>			
Low Input Voltage Switchover Value	90VAC or 77VAC (Selectable)		
AC Input Voltage	120 VAC + 12 volts / - 30 or -43 volts (selectable)		
AC Input Frequency	60 Hz +/- 5 Hz		
<b>Transfer Switch transfer time</b>	30 ms		
<b>System</b>			
Ambient Temperature	Continuous output at -40 to +105 degrees F (-40 to +40 degrees C)		
Cooling Air	Thermostatically controlled exhaust fan		
Enclosure	White painted aluminum with non-corrosive hardware		
Dimensions All Models	8.4"H x 17.5"W x 14.0"D		
Unit Weight	60 lbs	75 lbs	75 lbs

## 1.3 Standard Features

### 1.3.1 IQ Series Standard Features

1. True RMS regulated 120 volt AC 60 Hz Quasi-sine wave output
2. Output Short circuit / overload protection through electronic sensing
3. Output circuit breakers
4. Automatic shutoff for Low Battery
5. Automatic shutoff for Overload
6. Automatic momentary shutoff/restart for Over Temperature
7. All controls accessible from the front
8. AC input/output hardwire box
9. Load Demand including Automatic Throttle Control (1 amp ground signal)
10. Load Demand Enable/Disable Switch
11. Built-in GFCI duplex receptacle protected by a 15 amp circuit breaker.
12. Optional Remote Operating Panel and Remote ON/OFF Switch (capable of single wire control)

### 1.3.2 Additional Features on inverter models (example: IQ12-2600)

1. Three output circuits with 15 amp, 20 amp and 30 amp output circuit breakers

### 1.3.3 Additional Features on “inverter/charger” models (example: IQC12-2600)

1. Three Stage Battery Charger
2. Manually initiated Equalize Charging Cycle
3. Adjustable charge rate
4. Settings for charging wet or gel batteries
5. No minimum battery voltage required for charging (will charge a dead battery)
6. Jack for optional Battery Temperature Compensation Sensor (not available as of this printing)
7. Automatic Power Management (charger power control to prevent overloading the AC source)
8. Optional Automatic Power Management Panel
9. Automatic Transfer Switch with 5 second acceptance time delay
10. Accepts one or two 30 amp AC input circuit
11. Inverter Disable Switch to allow passthrough and battery charging only
12. Charger Disable Switch to allow passthrough only
13. Passthrough capability while battery is disconnected
14. Low AC input voltage tolerance selectable between 90VAC and 77VAC
15. Selectable Ambulance Mode to prevent automatic inverter startup upon loss of AC input power

**Please note:** The Battery Charger, Automatic Transfer Switch and Automatic Power Management are operational only when AC input power (shore power) is present.

## 1.4 Accessories

Part Number	Name	Description
03644	<b>Fuse</b> , Bussmann ANL-250	250 amp DC fuse for IQC24-3600 and for 1/0 charge cable
04523	<b>Fuse</b> , Bussmann ANN-400	400 amp DC fuse for IQ and IQC12-2600
03646	<b>Fuse</b> , Bussmann ANL-500	500 amp DC fuse for IQ and IQC12-3600
03637	<b>Fuse Holder</b> , Bussmann 4164	Fuse holder for Bussmann ANL and ANN fuses
IQ-SWR	<b>Single Wire Remote Control</b>	Most popular remote control. Accepts vehicle ignition voltage signal to provide inverter function (not charger) ON/OFF control. . For use with all IQ and IQC models.
D08514	<b>Remote Control Panel</b>	Remote Control Panel 4¼”H x 5½”W with ON/OFF Rocker Switch, Indicator Lights and 50ft 8 pin 1:1 modular cord*
D07917	<b>Remote Toggle Switch</b>	SPDT Center OFF Momentary Toggle Switch, 25ft cable and includes D07905 Remote Switch Adapter
D07905	<b>Universal Remote Switch Adapter</b>	Modular (phone jack) Adapter with screw terminals and 2ft modular cord*. For use with customer supplied ON/OFF switch(s). For 12-volt single-wire ON/OFF control use with Bosch Relay 05235. For systems requiring multiple switches use momentary SPDT center OFF switches.
05235	<b>Bosch Relay</b> , 12 volt 30 amp	Automotive 12-volt SPDT relay with 30-amp contacts
D07934	<b>Remote APM Panel</b>	Remote Automatic Power Management Panel w/ 25ft cord*
D08546	<b>Cord Set</b> , 20 Amp AC Output	120 volt, 20 amp, Twist-lock Receptacle (NEMA L5-20R) on 1' long 12/3 SO cable. The set includes a mating NEMA L5-20P plug
D07924	<b>Cord</b> , 30 Amp AC Output	120 volt, 30 amp, Twist-lock Receptacle (NEMA L5-30R) on 1' long 10/3 SO cable. (Does not include mating plug.)
D07923-01	<b>Cable Set</b> , 1/0 Quick Connect	For use with customer supplied 1/0 DC cable. The set includes 18" long 4/0 DC input cable with polarized 350 amp quick connector and mating connector for 1/0 cable.
D07923-02	<b>Cable Set</b> , 2/0 Quick Connect	For use with customer supplied 2/0 DC cable. The set includes 18" long 4/0 DC input cable with polarized 350 amp quick connector and mating connector for 2/0 cable.
D07923-03	<b>Cable Set</b> , 3/0 Quick Connect	For use with customer supplied 3/0 DC cable. The set includes 18" long 4/0 DC input cable with polarized 350 amp quick connector and mating connector for 3/0 cable.
D07923-04	<b>Cable Set</b> , 4/0 Quick Connect	For use with customer supplied 4/0 DC cable. The set includes 18" long 4/0 DC input cable with polarized 350 amp quick connector and mating connector for 4/0 cable.

\*The orientation of the wire colors in IQ Series modular cord connectors are identical, not mirrored.

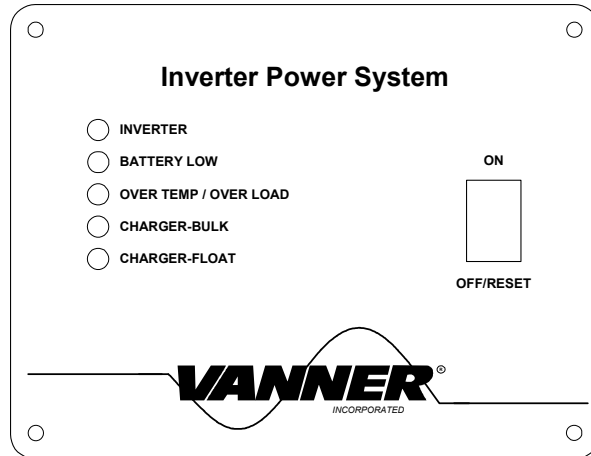

Remote Control Panel D08514

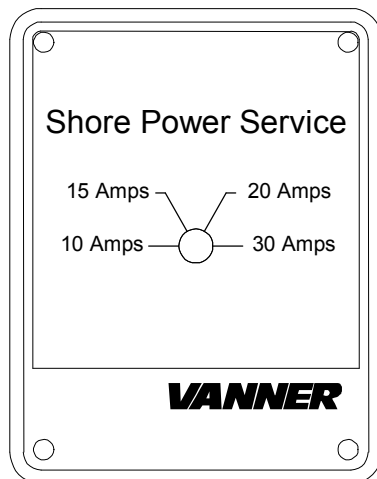

D07934 Remote APM Panel  
built before Inverter/Charger  
serial number 02154-049638

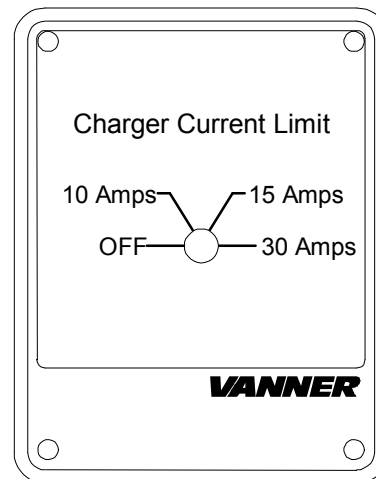

D07934 Remote APM Panel  
built after Inverter/Charger  
serial number 02154-049638

**Remote APM (Automatic Power Management) Panel D07934**

The optional Remote APM Panel, part number D07934, is designed for use with Inverter/Charger Models IQC12-2600, IQC12-3600 and IQC24-3600.

**Label Clarification:** The D07934 Remote APM Panel has been built with two different labels. The label was updated to show APM values for IQC Inverter/Chargers effective serial number 02154-049638 (June 3, 2002). APM values selected by the Remote APM Panel are determined by the IQC inverter/charger serial number regardless of the APM Panel label.

## 1.5 Definitions

### 1.5.1 Quasi Sine Wave:

Quasi Sine Wave Inverters are sometimes called "modified sine wave inverters" or "modified square wave inverters." Quasi sine wave inverters produce an AC output wave different from the power produced by the electric utility companies and rotating generators. Although this waveform has a higher peak voltage than do square wave inverters, its peak voltage is not as high as a pure sine wave. Therefore, AC loads containing power supplies might not always operate properly on the quasi sine wave inverters.

### 1.5.2 Load Demand Feature and Load Demand Mode:

The Load Demand Feature is an energy conserving feature which allows the inverter to enter the 'Load Demand Mode' whenever the inverter is ON and the AC load has been less than 5 watts for approximately 5 seconds. While in the 'Load Demand Mode' the inverter does not produce 120 volts AC but instead produces pulses of reduced AC voltage, which the inverter uses to look for a load. When an AC load greater than 5 watts is sensed, the inverter will turn fully ON to produce 120 Volts AC. The 'Load Demand Mode' is often also described as 'stand-by mode' or 'sleep mode'. While in the 'Load Demand Mode' the inverter consumes approximately 140 milliamps of 12 volt DC power.

The Load Demand Feature can be turned OFF by setting *Selector Switch 2* to the OFF position. This will cause the inverter to remain fully ON, producing 120 Volts AC, whenever the inverter switch is ON and regardless of AC load. It is desirable to do this when the device being powered draws less than 5 watts. An example of such a device is a plastic pipe fusion machine, which draws less than 5 watts during the 'coupling cooling time'. With the Load Demand Feature turned OFF and operating no AC load the inverter consumes approximately 1.8 amps of 12 volt DC power.

### 1.5.3 Automatic Transfer Switch:

The Transfer Switch is a standard feature provided on all IQC models. The Transfer Switch automatically allows input power, from an external AC power source such as shore power or a generator, to pass through the inverter output circuit and be used to operate inverter loads.

### 1.5.4 Automatic Power Management:

The IQC's AC Input 1 is the source of AC power for battery charging and also may provide passthrough power for AC loads. The Automatic Power Management (APM) circuit monitors total AC amps on the IQC's AC Input 1 and reduces the battery charger's AC power consumption when necessary so that total AC1 amps do not exceed the APM Setting. The APM circuitry does not limit AC power passing through to AC loads. The default APM Setting is 30 amps. By using the optional D07934 Remote APM Panel the APM Setting can be adjusted to lower values. (More details can be found in the Automatic Power Management description of operation.)

### 1.5.5 Ambulance Mode:

The primary purpose of Ambulance Mode is to prevent the inverter from coming ON and running down the ambulance's battery when the shore power cord accidentally becomes unplugged.

In Ambulance Mode the IQC performs similar to Vanner's 20-1050CUL Ambulance inverter/charger. The charger will turn ON and shore power will pass through as soon as shore power is connected to AC1. (The ON/OFF Switch must be in the RUN position but the charger does not need to be manually turned ON.) When shore power is disconnected, the inverter will not turn ON until the ON/OFF Switch, or remote switch, is manually pushed to the Start position.

If Ambulance Mode is not selected the inverter/charger will function in **Standard Backup Mode**. In Standard Backup Mode the charger will not turn itself ON when shore power is connected. The inverter must already be ON or the charger must be 'started' by pushing the ON/OFF Switch to the Start position. In Standard Backup Mode, when shore power is disconnected the inverter will automatically come ON.

## 1.6 Important Safety Instructions

This manual contains important safety and operating instructions for the Vanner Power Group "IQ Series" Power Inverter and Inverter/Charger System as prescribed by Underwriters Laboratory (UL). The IQ Series Inverter and Inverter/Charger Family is listed as compliant with UL 458 (**only if the UL/CUL symbol is on the front of the unit**), Power Converters/Inverters and Power Converter/Inverter Systems for Land Vehicles. The Vanner Power Group "IQ Series" also is listed to the Canadian National Standard CSA – C22.2 No. 107.1 – 1951.

### SAVE THESE INSTRUCTIONS

- WARNING** This equipment employs components that tend to produce arcs and sparks. To prevent fire or explosion, DO NOT install in confined areas or compartments that contain batteries or flammable materials.
- WARNING** Risk of electrical shock. Use only the ground fault circuit interrupter (GFCI) receptacle(s) or circuit breaker(s) specified in the installation and operating instructions supplied with this inverter. Other types may fail to operate properly when connected to this equipment.
- CAUTION** Read owners manual BEFORE wiring or powering up.
- CAUTION** DO NOT cover or obstruct ventilation openings. DO NOT mount in zero-clearance compartments. Overheating may result which may diminish system capacity.
- NOTICE** The output of this device is not sinusoidal. The IQ SERIES inverter has a total harmonic distortion of 34.6 percent and maximum single harmonic of 24 percent.

## 1.7 General Precautions

1. Do not expose the Vanner IQ series Inverter to direct water spray or snow.
2. To reduce the risk of a fire hazard, do not cover or obstruct the ventilation openings.
3. Do not cover or obstruct ventilation openings. Do not install this unit in a zero clearance compartment. The result may be overheating which may diminish performance.
4. To avoid the risk of fire, electric shock, or injury to persons, do not use attachments not recommended or sold by the Vanner Power Group
5. Vanner recommends that all DC and AC electrical wiring be performed by a certified electrician or technician to ensure compliance with all proper national and local wiring regulations.
6. To avoid a risk of fire and/or electric shock, always verify wiring connections are in good electrical condition. All external conductors must use proper wire size to avoid dangerous overheating or diminished performance.

7. If the Vanner inverter system has been dropped or damaged in any way, do not operate until its operation has been verified to be safe by a qualified technician.
8. To reduce the risk of electric shock always disconnect the AC and DC connections to the Vanner Inverter system before attempting any maintenance. Simply turning the unit off does not prevent electric shock.
9. The Vanner “IQ Series” inverter system must be properly grounded in accordance with local and national codes and ordinances before operation. For most installations the negative (ground) conductor should be bonded to the grounding system at one and only one point in the system.
10. Do not disassemble the IQ Series Inverter/Charger; see the service section of this manual for instructions on obtaining service for the IQ Series Inverter/Charger. Attempting to service the unit yourself may result in a risk of electrical shock or fire

## 1.8 Explosive Gas Precautions

1. This equipment contains components, which tend to produce arcs or sparks. To prevent fire or explosion do not install in compartments containing batteries or flammable materials or in locations, which require ignition, protected equipment. This includes any space containing gasoline-powered machinery, fuel tanks, or joints, fittings, or other connection between components of the fuel system.
2. Working in the vicinity of a lead-acid battery is dangerous. Batteries generate explosive gases during normal battery operation. To reduce the risk of battery explosion, follow these instructions and those published by the battery manufacturer and the manufacturer of the equipment in which the battery is installed.

## 1.9 Precautions When Working with Batteries

1. Always have someone within range of your voice to come to your aid when you work near a lead-acid battery.
2. Have access to plenty of fresh water and soap nearby in case battery acid contacts skin, clothing, or eyes.
3. Always wear complete eye protection and clothing protection. Avoid touching eyes while working near batteries.
4. If battery acid contacts skin or clothing, wash immediately with soap and water. If acid enters eye, immediately flood eye with running cold water for at least 20 minutes and get medical attention immediately.
5. NEVER smoke or allow a spark or flame in the vicinity of batteries. Gases produced by batteries are explosive.
6. Be careful when working with metal tools around batteries. Potential for spark exists or short-circuit of the battery or other electrical part that may cause an explosion.
7. Never charge a frozen battery. Attempt to warm battery above 32 degrees F before charging.

## 2 COMPONENT IDENTIFICATION and DESCRIPTION of OPERATION

Numbered paragraphs in this section correspond with Figure 2 – Inverter Illustration.

**Figure 2 IQ Series Illustration**

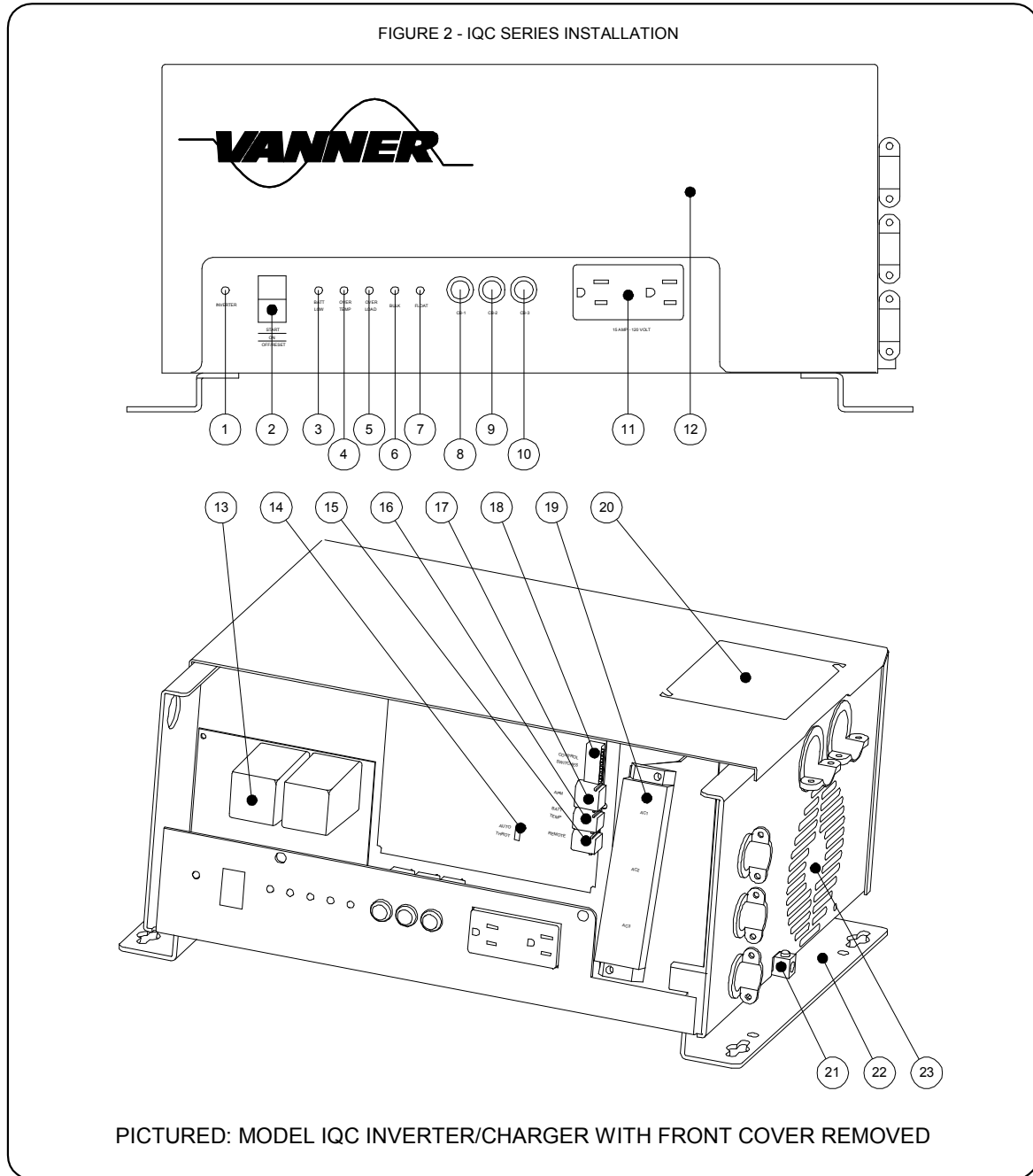



## 2.1 (1) INVERTER Indicator Light

<u>Light Action</u>	<u>Description</u>
Green Light is OFF	Inverter circuit is OFF
Solid Green	Inverter is ON (producing AC power)
Fast Blinking Light (2 blinks per second)	Inverter is in Load Demand Mode

### **IQC Models (Inverter/Charger) in Charger Mode (This is when shore power to AC1 is ON.)**

Slow Blinking Light (1 blink per second)	Shore power is supplying AC power to the loads.
---	---

## 2.2 (2) ON/OFF Switch

The ON/OFF switch is a three-position rocker switch whose function is similar to the ignition switch on a vehicle. The low position is OFF/RESET. The middle position is ON (RUN). The high position is START, which is a momentary position.

### **IQ Models and IQC Models in Inverter Mode (This is when shore power is OFF.)**

OFF	In the OFF position the inverter is locked OFF. The indicator lights do not function and the inverter cannot be started from a remote switch. (Please note that this <u>does not disconnect power</u> from the inverter system.) Approximately 50ma is being drawn from the battery.
ON (RUN)	The switch must be in the ON (RUN) position for the inverter to be operational and for remote switch capability to be enabled.
START	Press the switch to the START position to start inverter operation.
RESET	If the inverter has turned itself OFF due to overload or low battery, the switch must be moved to OFF/RESET before the inverter can be restarted.

### **IQC Models (Inverter/Charger) in Charger Mode (This is when shore power is ON.)**

OFF	<p>In the OFF position the charger is locked OFF. The indicator lights do not function and the charger cannot be started from a remote switch. (Please note that this <u>does not disconnect power</u> from the inverter system.) No power is being drawn from the battery.</p> <p>Power on AC input is being monitored for proper voltage and frequency but power will not be accepted for charging or passthrough.</p>
ON (RUN)	The switch must be in the ON (RUN) position for the charger to be operational and for remote switch capability to be enabled.

**START** Press the switch to the START position to initiate acceptance of AC input for charger/transfer switch function and to start charger operation. This is necessary when the inverter is in Standard Mode but not necessary when in Ambulance Mode.

### 2.3 (3) BATTERY LOW Indicator Light

<u>Light Action</u>	<u>Description</u>
---------------------	--------------------

Solid Red	Inverter is On and battery voltage has decayed to 11 or 22 volts DC warning imminent inverter shutdown unless battery voltage is increased by charging.
-----------	---

Blinking Red	Battery has decayed to 10.5 or 21.0 volts DC causing inverter shutdown. Battery must be recharged. Then, Inverter On/Off switch must be reset to activate.
--------------	--

### 2.4 (4) OVER TEMPERATURE Indicator Light

<u>Light Action</u>	<u>Description</u>
---------------------	--------------------

Solid Red	Inverter or Charger has shutdown due to over temperature. Shutdown may be caused by high ambient temperature or restricted cooling airflow to the inverter. Shutdown sensor will automatically reset when the unit has cooled.
-----------	--

### 2.5 (5) OVERLOAD Indicator Light

<u>Light Action</u>	<u>Description</u>
---------------------	--------------------

Solid Red	The inverter is ON and the inverter's AC output circuitry is sensing an overload condition. If the AC load is not reduced the inverter will shut itself OFF.
-----------	--

Blinking Red	The inverter is Off. An overload has occurred and the inverter has shut off to protect itself. Once shut off, the inverter On/Off switch must be cycled to reset the unit.
--------------	--

### 2.6 (6) BULK CHARGE Indicator Light

#### **IQC Models**

The Bulk Charge indicator light is present on all models but is functional only on IQC Models. (See 'Battery Charger Theory of Operation' for battery charging performance details.)

<u>Light Action</u>	<u>Description</u>
---------------------	--------------------

Blinking Yellow	The unit is in Charger Mode (shore power is ON) and the charger is in either the BULK STAGE or ABSORPTION STAGE of the battery charging cycle.
-----------------	--

Solid Yellow	The unit is in Charger Mode (shore power is ON) and the charger is in the EQUALIZATION CYCLE.
--------------	---

## 2.7 (7) FLOAT CHARGE Indicator Light

The light is present on all models but is functional only on IQC Models.  
(See 'Battery Charger Theory of Operation' for charger performance details.)

### IQC Models

<u>Light Action</u>	<u>Description</u>
Solid Green	The unit is in Charger Mode (shore power is ON) and the charger is in the FLOAT STAGE of the battery charging cycle.
Blinking Green	Both the Battery Charger and Inverter functions have been turned OFF by turning Program Switches 5 and 4 to the left position. Shore power is ON. (See PROGRAM SWITCH description.)

## 2.8 (8) AC CIRCUIT BREAKER

## 2.9 (9) AC CIRCUIT BREAKER

## 2.10 (10) AC CIRCUIT BREAKER

### IQ Models (Inverter Only)

(8)	CB1	20 amp	Protects AC output circuit
(9)	CB2	15 amp	Protects built-in GFCI receptacle.

### IQC Models (Inverter/Charger)

(8)	CB1	30 amp	Protects AC input circuit
(9)	CB2	15 amp	Protects built-in GFCI receptacle.
(10)	CB3	30 amp	Protects AC output circuit

## 2.11 (11) AC OUTPUT RECEPTACLE

GFCI convenience receptacle, 120vac 1800 watt maximum output, protected by 15 amp circuit breaker CB2. The GFCI is a 15 amp receptacle and is protected by a 15 amp breaker.

## 2.12 (12) FRONT COVER

BE SURE THE INVERTER IS TURNED OFF AND ALL EXTERNAL SOURCES OF POWER ARE TURNED OFF BEFORE REMOVING THE FRONT COVER. The Front Cover must be removed to access the program switches and remote control connections located on the control circuit board.

## 2.13 (13) AUTOMATIC POWER TRANSFER SWITCH

### IQC Models only

The Automatic Power Transfer Switch is furnished only on IQC Models and consists of a circuit board containing two relays. (IQ Models do not have the transfer switch but instead have a terminal strip in this location.) See Automatic Power Transfer Switch Theory of Operation for performance details.

## 2.14 (14) AUTOMATIC THROTTLE CONTROL TERMINAL J31

### All Models

Terminal J31 is provided to be used on utility vehicles where the inverter needs to operate continuous heavy AC loads and the vehicle is equipped with an Automatic Throttle. Use J31 to turn ON the Auto Throttle to insure that the vehicle alternator is producing maximum output whenever the inverter is powering a load.

J31 is controlled by the Load Demand circuit therefore Programming Switch 2 must be in the ON position when Terminal J31 is used.

J31 is a 1/4" spade terminal located in the lower right midsection of the control circuit board. The terminal is designed to provide ground control for a Bosch relay, Vanner part number 05235 or equal. Install a 1 amp fuse in line near the inverter.

## 2.15 (15) REMOTE CONTROL JACK J9

### All Models

Jack J9 is an 8 wire modular jack for use with optional Remote Control Switch, Remote Control Adapter or Remote Operating Panel.

## 2.16 (16) BATTERY TEMPERATURE COMPENSATION CONTROL JACK J1

Jack J1 is a 4 wire modular jack for use with optional Battery Temperature Sensor. The Battery Temperature Sensor reduces charging voltage when the batteries are in a high ambient temperature.

## 2.17 (17) AUTOMATIC POWER MANAGEMENT (APM) Panel JACK J8

(Jack J8 is present on all models but is functional on IQC Models only.)

### IQC Models

Jack J8 is a 4 wire modular jack for use with optional Remote Automatic Power Management (APM) Panel, Vanner part number D07934. The optional Remote APM Panel allows the APM current setting to be adjusted to suit the circuit breaker at the shore power source. Before inverter serial number 02154-049638 the APM values are 10 amps, 15 amps, 20 amps, or 30 amps. After inverter serial number 02154-049638 the APM values are zero amps, 10 amps, 15 amps, and 30 amps. See Automatic Power Management theory of operation for performance details.

**Figure 3 Programming Switch Instruction Label**

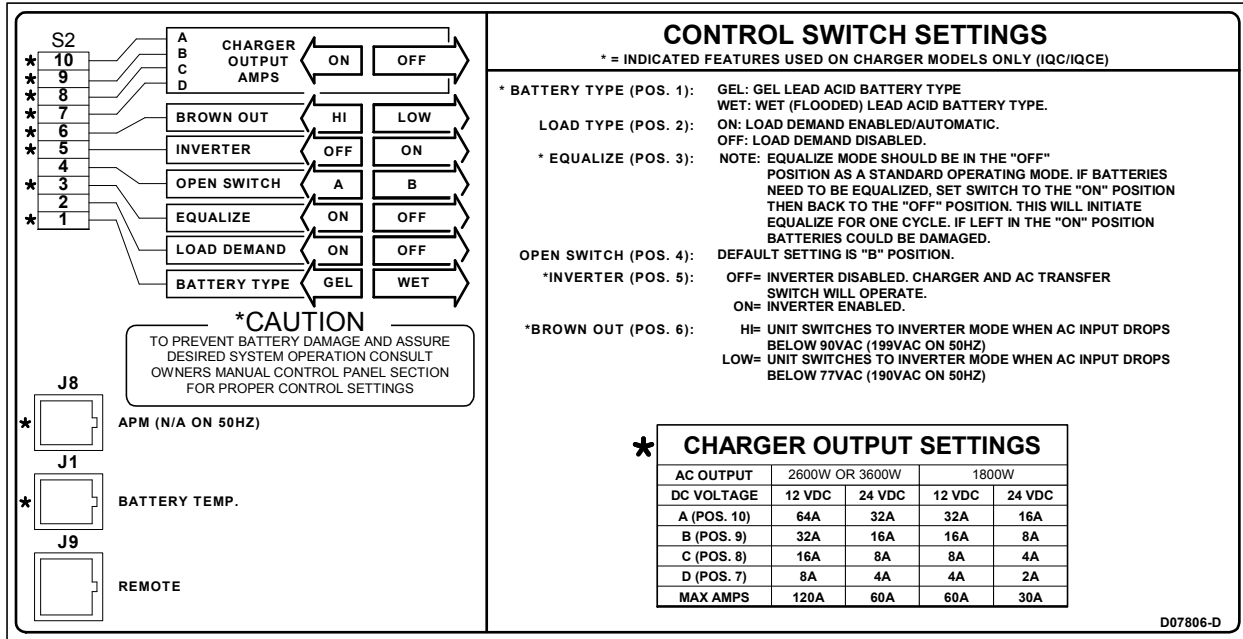

**2.18 (18) PROGRAMMING CONTROL SWITCHES**

**IQ Models (Inverter only) Only Switch 2 is functional**

Switch 2 allows Load Demand to be turned ON or OFF.

**IQC Models (Inverter/Charger)**

All positions of the Programming Switch are functional on IQC Models.

Switch#	Position Left / Right	Function
10	Add 64 amps / 0	Switches 7 through 10 add to set the bulk charge rate.
9	Add 32 amps / 0	
8	Add 16 amps / 0	
7	Add 8 amps / 0	
6	90VAC / 77VAC	Low AC Input Voltage switchover tolerance value.
5	Disable / Enable	Disable Inverter operation. While the inverter is disabled the battery charger and transfer switch remain operational.
4	Disable / Enable	Disable Charger operation. The charger will be disabled only if the inverter is also disabled at dip switch 5. The transfer switch remains operational.
3	Start / Off	Equalize Start
2	Enable / Disable	Load Demand
1	Gel / Wet	Battery Type



The battery charger will draw 27.5 AC amps from shore power when the 12 volt charging output is 120 amps. A lower charger setting will draw proportionally lower AC input amps.

## 2.19 (19) 120 VOLT AC WIRING

**CAUTION:** BE SURE THE INVERTER IS TURNED OFF AND ALL EXTERNAL SOURCES OF POWER ARE TURNED OFF BEFORE ACCESSING THE AC INPUT/OUTPUT WIRING.

### General

AC input and output wires are to be routed through the three strain relief cable clamps located on the right side of the unit.

The installer should verify that all AC circuits connected to the unit output are an insulated neutral type as required by the National Electrical Code (NEC) article 551.

Refer to local codes for correct AC wire size appropriate for your inverter system and loads.

### Ground Fault Circuit Interruption

Some installations require the installation of Ground Fault Circuit Interrupter (GFCI) type circuit breakers in the AC distribution system. Because the output waveform of the inverter is not the same as that supplied by a generator or the utility, some GFCI devices do not function properly. The following list of GFCI circuit breakers have been tested and function properly with this inverter system.

**Table 6 - Approved 15A Ground Fault Current Interrupters (GFCI Recommendations)**

<u>Manufacturer</u>	<u>Manufacturer Part Number</u>
Hubbell	GF5252W
Hubbell	GF5252
Leviton	6490I
Pass and Seymour	1591R or 1595W

### IQ Models (Inverter only)

- General AC1, AC2 and AC3 are all output circuits.
- AC1 AC output circuit protected by 20 amp circuit breaker CB1.
- AC2 AC output circuit protected by 15 amp circuit breaker CB2. (On inverter-only models, the built-in GFCI receptacle receives its power from AC2.)
- AC3 AC output circuit protected by 30 amp circuit breaker CB3.

### IQC Models (Inverter/Charger)

- AC1 This is the primary AC input circuit and is protected by 30 amp circuit breaker CB1. Input voltage and frequency are monitored for proper tolerance at all times. Input power supplied to AC1 is used for battery charging, and is used for pass-through to AC3 if power is NOT present on AC2.

Note: Be careful that the AC input power required for battery charging combined with the pass-through power required for the AC loads does not overload the shore power AC source.

The battery charger will draw approximately 30 AC amps from shore power through AC1 when the 12 volt charging output is 120 amps. AC input amps to DC output amps remains approximately the same ratio. The charger will draw proportionally lower AC input amps from shore power when the charger output amps are lower. Read the Automatic Power Management section in this manual which applies only to AC1. If desired, use the optional Remote Automatic

Power Management (APM) Panel, Vanner part number D07934, to reduce the maximum AC input amps the charger can draw.

- AC2 Secondary (and optional) 30 amp AC input circuit which is used only for pass-through to AC3. This allows the full 30 amps input on AC1 to be used for battery charging. AC2 accepts input power only when AC1 is receiving AC input power.

**Caution: AC power supplied to AC2 MUST BE IN-PHASE with the AC power supplied to AC1. (When two circuits are in-phase there will be zero AC volts between AC1 hot and AC2 hot.) The transfer switch components will be destroyed if AC1 input and AC2 input are not in-phase. (If not in-phase the multi-meter would show 240vac between AC1 hot and AC2 hot.)**

- AC3 AC output circuit protected by 30 amp circuit breaker CB3. (On charger models, the built-in GFCI receptacle receives its power from AC3 via CB2.)

**Notice:**

1. When the inverter/charger is connected to an external power source, the internal circuit breakers (CB1, CB2 and CB3) are considered supplemental and do not qualify as “branch rated” circuit breakers. External AC circuits carrying power to and from the unit must conform to National Electric Code and any other applicable codes.

2. The Automatic Power Transfer Switch switches both hot and neutral. For safety purposes the inverter output neutral (terminal #8) is connected to the inverter chassis ground only when the unit is in inverter mode. This is a requirement of the National Electric Code for all systems of this type that neutral should be connected to ground only at the source of AC power, which is the inverter when in inverter mode. When an external AC input (shore power, generator) is available, the IQC Transfer Switch system breaks the connection between neutral and inverter chassis ground. The neutral-to-ground connection for pass-through power is then provided by the AC input source.

## 2.20 (20) DC INPUT WIRING COMPARTMENT

**All Models**

The DC wiring enclosure is located on the top right side of the inverter and contains 5/16 “ diameter studs to permit connection of two cables from the battery.

**BE AWARE** that, as a large number of capacitors become charged upon completion of the DC circuit, **THERE WILL BE A LARGE SPARK** when the last battery connection is made. The spark is normal and will occur every time the batteries are connected.

## 2.21 (21) GROUND WIRING LUG

**All Models**

This is a compression type terminal requiring only a flat blade screwdriver to make the connection. This terminal has been provided for safety to prevent possible shock hazards. Connect a #8 AWG minimum size wire to this terminal and then to the vehicle chassis ground or to earth ground.

## 2.22 (22) MOUNTING BRACKETS

### All Models

The IQ Series utilizes detachable mounting brackets, which offer a variety of mounting configurations.

**WARNING:** Do not remove the plastic mounting feet. All units requires 3/4" space minimum under the unit to allow air flow for proper cooling.

## 2.23 (23) COOLING FAN

### All Models

The cooling fan exhausts air out through the cooling fan opening. Cool air is drawn in from the bottom and left sides of the unit. Obstruction of the intake or exhaust air flow will create overheating problems, which will diminish the performance of the unit.

## 3 INSTALLATION

### 3.1 Unpacking the Inverter

Inspect the shipping container and equipment for loose or damaged parts. If any damage is found, immediately notify the freight carrier.

### 3.2 Inverter Installation Considerations

The wiring of your inverter installation should conform to the National Electric Code (NEC) and any other state or local codes in effect at the time of installation. These codes have been written for your protection and their requirements should be followed.

#### Mounting

Locate a secure, dry, flat horizontal or vertical surface large enough to mount the inverter. The location should be as close to the battery as possible without being in the same compartment and should provide adequate ventilation to maintain room temperature while the inverter is operating. The location must allow unobstructed cooling air flow at sides and bottom of the unit, and the location must be free from road spray, dripping water or other moisture contamination. A recommended minimum clearance of 4 inches (102 mm) should be maintained on all sides of the unit.

### 3.3 DC Wiring Considerations

**BE AWARE** that, as a large number of capacitors become charged upon completion of the DC circuit, **THERE WILL BE A LARGE SPARK** when the last battery connection is made. The spark is normal and will occur every time the batteries are connected.

1. The DC cables should be as short as possible. It is more electrically efficient to run the lower current AC wiring longer distances (see battery cable sizing table for proper size)

2. Route the DC positive and negative cables as close together as possible, and use cable ties to keep them together. This reduces some electromagnetic radiation that could interfere with some sensitive electronics.
3. On vehicle installations do not use the vehicle chassis as the DC negative conductor. Use a cable the same size as the DC positive to go directly from the inverter to the battery negative.
4. Route the AC and DC power wiring separately, and with as much physical separation as possible, from low voltage wiring such as audio and video signal wires.
5. DC power input cables which pass through steel or other ferrous metal walls need to pass through the same hole. If two holes are required cut a slot connecting the two holes to prevent a transformer effect.

**WARNING:** Do not allow wire fragments or metal shavings to fall into the DC wiring compartment or to enter the inverter in any way.

### DC INPUT WIRING CONNECTIONS

A DC fuse is required to properly protect the inverter.

The DC wiring enclosure is located on the top right side of the inverter system to permit connection of the two cables from the battery. Cable clamps are provided to secure the cables after they are terminated in the wiring enclosure. A removable cover allows access to the wiring enclosure.

DC input studs have been provided to accommodate crimp or compression lugs (Vanner part no. 04505, ILSCO part no. TZ-250 #6-250 MCM or similar) with 5/16" hole with battery cable up to 4/0 AWG cable. Good DC connections are critical for the performance and safe operation of the inverter system. Torque the DC input stud nut to 119 – 158 in. lbs. and repeat torque procedure after 30 days. The positive and negative cables enter the compartment through separate strain reliefs located at the upper right side of the unit.

Table below shows the recommended minimum cable size that should be used. Wire sizing charts published in the NEC may allow a greater amp capacity than we recommend. We have sized the cable for a maximum voltage drop to maintain better performance of your inverter installation. For best performance, wire the DC negative directly back to the battery, and in the case of a mobile installation, do not use the vehicle chassis as the DC negative conductor.

The wiring of your inverter installation should conform to the National Electric Code (NEC) and any other state or local codes in effect at the time of installation. Article 551 of the NEC requires any DC cable from a battery, which measures longer than 18 inches along its length, be protected by a fuse.

Figure 4 DC Cable and Fuse Sizing Chart

<b>IQ SERIES DC Cable and Fuse Sizing Chart</b>				
<b>Model Number</b>	IQ12-2600 IQC12-2600		IQ12-3600 IQC12-3600	IQC24-3600
	<b>Distance from battery to inverter in feet</b> (Length of cable needed is 2 times the distance.)			
<b>Cable Size</b>				
1/0	NR		NR	8
2/0	NR		NR	13
3/0	10		NR	16
4/0	14		10	20
250MCM	16		12	20
<b>Fuse</b>				
Bussman Fuse Vanner P/N	ANN400 04523		ANL500 03646	ANL250 03644
Bussman Fuse Holder Vanner P/N	4164 03637		4164 03637	4164 03637

### 3.4 DC Wiring Installation Procedure

Steps

1. Turn the inverter OFF and disconnect power to the wiring harness. Make sure power to the inverter is disconnected. Verify that the inverter is turned OFF (the ON-OFF/RESET Inverter switch is in the OFF-RESET position).
2. Select a location for the unit. An ideal installation location has the following characteristics:
  - a. Close to the battery (usually within six feet).
  - b. Protected from the weather.
  - c. Well ventilated.
3. Remove the cover plate on the DC cable compartment ( #20 ) exposing the positive and negative terminal studs.
4. Prepare DC cable end with appropriate terminals (crimped or compression lugs), verify battery positive cable is disconnected from battery, and insert DC cable through strain relief openings leading to DC cable compartment. Tighten DC cable stud nuts to 119-158 in. lbs. of torque. Tighten the two strain relief cable clamps.
5. After installation of DC cables, inspect the DC cable compartment to ensure that no foreign particles (copper wire fragments) are present.
6. Replace the cover plate over the DC cable compartment.
7. Tighten DC cable stud nuts to 119-158 lbs of torque.
8. Route the negative and positive DC input cables from the inverter to the battery but do not connect to battery at this time. Protect cables with grommets or other appropriate means where they may contact hard, sharp edges throughout the installation path.

9. Install the in-line fuse. Install an in line fuse in the red, positive DC input cable between the battery and inverter, within 18 in. of the battery or DC wiring bus system. Be sure to mount fuse in easily accessible location for replacement. It is also “good practice” to note on the inverter to check the fuse condition before involving any troubleshooting procedure.
10. Connect Bonding Lug. ( see #21 ). Use AWG No.8 or larger copper conductor to connect chassis bonding lug to the vehicle chassis and/or earth ground.
11. Do not connect the inverter to the battery at this time. Final battery connections will be made after all installation issues have been inspected.

### 3.5 AC Wiring Installation Procedure

1. Remove the front cover of the inverter exposing the AC wiring compartment. Identify location of AC wiring terminal block (see item 2.19).
2. Insert the AC line (input) and load (output) wires through the appropriate strain reliefs into the AC wiring compartment, and tighten the strain relief with a screwdriver.
3. Connect the AC output wire to the appropriate Hot, Neutral, and Ground terminals inside the AC wiring compartment using suitable wire terminators such as crimped spade or ring terminals. Torque terminal strip screws to 16 inch pounds.
4. Connect AC Input(s) (IQC Models only). Connect one 30 amp AC input circuit to AC1. If desired connect an additional 30 amp AC input circuit to AC2. **If using two AC input circuits they must be in-phase (zero volts between AC1 hot and AC2 hot). The transfer relays will be destroyed if AC1 and AC2 are out-of-phase.** Connect input wires to the appropriate Hot, Neutral, and Ground terminals for AC1 and AC2. Torque terminal strip screws to 16 inch pounds..Replace the AC wiring compartment cover.  
NOTE: If only a single 30 amp supply source will be used, it is only necessary to connect AC1 input (no connection to AC2) to a single branch-rated circuit breaker in the main AC distribution panel(from shore/utility power or form a 10kW or larger generator). If two 30 amp supply circuits are to be used, connect AC1 and AC2 to two separate 30 amp branch-rated AC circuit breakers in the main AC input distribution panel. See Section 5.2, AC Power Transfer Switch for more details.
5. Verify Installation. Verify all connections are tight and secure for maximum safety and performance.

### 3.6 Remote Monitor and Control Panel Installation

#### *Unpacking the Remote Monitor/Control Panel*

Inspect the shipping container and equipment for loose, damaged, or missing parts. The remote panel includes a 20-ft. interconnecting cable. If any damage is found, immediately notify the freight carrier.

#### Steps

1. Locate a suitable place to install the remote panel such as a flat surface near the power control/distribution panel or driver's compartment. The mounting surface should have sufficient space to accommodate the remote panel's depth and cable routing. Cut surface material large enough to accommodate the remote control box leaving sufficient surface material to attach panel with #8 mounting screws.
2. Route the 20-ft. interface cable from the remote panel mounting area to the inverter being careful to avoid unprotected sharp corners or moving parts.
3. Plug the interface cable into the inverter's wiring panel (RJ-11 telephone-type jack labeled J9 on the control printed circuit board). Plug the other end of the cable into the rear of the remote panel.
4. Mount the remote panel using four #8 screws.

### 3.7 Remote Automatic Power Management (APM) Panel Installation

#### *Unpacking the Remote Automatic Power Management (APM) Panel*

Inspect the shipping container and equipment for loose or damaged parts. If any damage is found, immediately notify the freight carrier.

#### Steps

1. Locate a suitable place to install the APM panel such as a flat surface near the power control/distribution panel, shore power switch, or driver's compartment. The mounting surface should have sufficient space to accommodate the remote panel's depth and cable routing. Cut surface material large enough to accommodate the remote control box leaving sufficient surface material to attach panel with # 8 mounting screws.
2. Route the 20ft. interface cable from the remote panel mounting area to the inverter.
3. Plug the interface cable into the inverter's wiring panel (RJ-11 telephone-type jack labeled J8 on the control printed circuit board).
4. Plug the other end of the cable into the rear of the APM panel.
5. Mount the remote panel using four # 8 screws.

## 4 SYSTEM START-UP AND TESTING PROCEDURES

**WARNING: THESE PROCEDURES ARE TO BE PERFORMED ONLY BY A QUALIFIED INSTALLER.**

After the IQ series inverter has been properly mounted with sufficient ventilation, DC cables have been connected, AC wiring has been completed, and all remote connections have been checked, the Start-up and Testing procedure may now be performed .

### 4.1 Inverter Start-up and Testing

1. Place the System On/Off switch on the inverter and remote LED panel in the OFF position.
2. Remove the front cover of the inverter to access the Programming Switch.
3. Place the Load Demand switch on the internal Programming Switch 2 to the ON position to test Load Demand function. It can be changed later if this feature is not used.
4. Verify that the external GFCI breaker, breakers, or receptacles are reset and connect an AC load, such as a 100-Watt light.
5. FOR IQC MODELS - Place the Wet/Gel Setup switch to the correct position for the installed battery type and place the Equalizer Setup switch to the OFF position.
6. Connect both battery cables to battery and turn on the battery DC power to the inverter (if battery switch is used).
7. FOR IQC MODELS - Do not connect shore/utility (generator) power at this time.
8. Place the System On/Off switch on the Inverter panel to the START position.

9. Place the System On/Off switch on the Remote panel (if used) to the ON position.
10. Plug AC output test light (eg. 100 watt trouble light) into 15A convenience receptacle and turn on to verify inverter produces AC power and the Load Demand function powers up from stand-by mode. Applying any AC load greater than 5 Watts should start inverter from Load Demand “stand by” mode.
11. FOR IQC MODELS - Connect and activate AC shore/power (or generator).
12. FOR IQC MODELS – When shore/utility power (or generator) has been connected the inverter the following should occur:  
  
If AC test light is off.
  - Inverter LED will blink slowly
  - Charge Bulk or Charge Float mode LEDs will illuminate. (If the battery is fully charged, it will advance from Bulk mode to Float mode after a time delay).  
If AC test light is on.
  - Inverter LED will blink.
  - Battery charge stage LEDs will illuminate as described above.
  - The AC output test light should be on, indicating the presence of shore power and correct operation of the AC Transfer switch.
13. FOR IQC MODELS - Disconnect the AC shore power input. The AC output test light blinks momentarily, indicating the operation of the Transfer switch connection to connect the AC loads to the inverter output.
14. The Inverter LED on the inverter control panel has a solid green light indicating correct inverter operation. At this point, apply AC loads up to the models rated capacity to verify full-power operation.
15. Disconnect all AC loads. The Inverter LED blinks, indicating that the inverter has returned to Load Demand mode.
16. FOR IQC MODELS - Determine the correct charger output amps and place the Programming Switch (#18) positions to match this value. Multiple switches can be activated at the same time to combine values.

For 12-Volt models, the output amps corresponding to the switch positions are:

A	8 Amps
B	16 Amps
C	32 Amps
D	64 Amps

For 24-Volt models, the output amps corresponding to the switch positions are:

A	4 Amps
B	8 Amps
C	16 Amps
D	32 Amps

Determine the combined value of switches that match the desired charger output amps and place these switches to the ON position. For example for a charger output of approximately 80 Amps,

the 64-Amps and 16-Amp switch positions would be ON and the 8-Amp and 32-Amp switch positions would be OFF.

If the Load Demand function is not appropriate for the intended application, reset the Load Demand Switch, Programming Switch 2, to the OFF position. This will allow the inverter to be fully On continuously unless switched off with the On/Off front panel switch or remote control.

Replace front cover of the inverter.

## 4.2 Procedure to Check Battery Charger Operation

Due to the amount of time to perform this procedure, verifying the battery charger function, it may be postponed to a convenient time.

To test the battery charger operations, first discharge the battery by placing a large AC load (approx. 50% of the unit's rated capacity) on the system and operating the inverter with shore power off. The AC load will discharge the battery over a time relative to the amount battery capacity, size of load, and ambient temperature.

When the battery charge level is low, the Battery Low LED turns on and will stay on until the battery voltage has dropped to the Battery Low shutdown stage the inverter shuts off and the LED begins to blink. The battery voltage has decayed to 10.5 Vdc (or 21.0 Vdc for 24 volt models). Now, apply shore power and observe the battery charger operation. The system begins with the Charger-Bulk Light blinking, indicating bulk charge operation. This supplies a constant current charge output. Connect an ammeter to the DC cables between the inverter and the battery to monitor the current (DC amps), and a volt meter to the battery to monitor the battery voltage rising.

After some time, the battery voltage rises to the Absorption voltage (14.4 VDC for wet batteries or 14.1 VDC for gel batteries). The Charger-Bulk light continues to flash, indicating the charger is in Bulk or Absorption mode. The battery voltage remains constant (Absorption voltage value), and the charger output current tapers off. After approximately twenty minutes, the charge advances to Float mode. The Charger Float LED turns ON and the battery voltage drops to the float voltage value (13.2 VDC for wet batteries or 13.6 VDC for gel batteries). The charger will remain in this stage until shore power is removed or until the battery will again accept the bulk charge amperage.

## 5 THEORY OF OPERATION

### 5.1 Battery Charger Power Consumption

The battery charger will draw approximately 27.5 AC amps from shore power when the 12 volt charging output is 120 amps. A lower charger setting will draw proportionally lower AC input amps. Be careful that the AC input power required for battery charging combined with the passthrough power required for the AC loads does not overload the AC source. The optional Remote Automatic Power Management (APM) Panel, Vanner part number D07934, allows remote adjustment of the maximum AC input amps the charger can draw.

## 5.2 Battery Charger Operation

The IQ Series' Battery Charger incorporates an automatic, three-stage charger. This design enables the unit to automatically charge batteries, maintaining the battery's integrity and reducing the likelihood of premature failure. The battery charger is designed to be used with lead-acid type batteries including sealed and gel types, but not for nickel-cadmium (Ni-Cad) or nickel-iron types.

There are three automatic charge stages; Bulk, Absorption, and Float.

### Bulk Charge Stage

The Bulk Charge Stage (fixed current) provides a fixed charging current for rapid charging of the battery bank. The charger output current is adjustable in 8-Amp steps (4-Amp steps on 24-Volt systems), up to the maximum charger rating, to match the charging requirements of the battery. The Bulk Stage is initiated when the battery will accept the charging amps selected. As the battery accepts charge the battery voltage will rise to the charger's Bulk Voltage value, 14.4 VDC for flooded batteries, or 14.1 VDC for gel batteries (on 24-Volt systems 28.8 and 28.2 respectively). When battery voltage reaches the Bulk Voltage Value the Bulk Charging Stage is complete. At this point, the battery is approximately 80-percent charged.

### Absorption Charge Stage

During Absorption Charge Stage (fixed voltage), the charger's output voltage remains fixed at the Bulk Charge value and the output current will decrease as the battery becomes fully charged. The Absorption Stage ends after twenty minutes and the charger advances to the Float Stage.

### Float/Maintenance Charge Stage

When the charger enters Float Stage, its output voltage is reduced to the float voltage value 13.2 VDC for flooded batteries, or 13.6 VDC for gel batteries (on 24-Volt systems 26.4 and 27.2 VDC respectively). This setting is sufficient to keep the battery charged, but not so high as to boil or over-charge the batteries. The charger will remain in Float Stage until the battery will accept the Bulk Charge Output Amps selected.

### Equalization Cycle

This manually initiated cycle provides a 1 hour equalization charge at the Bulk Voltage level to boil the battery. This removes the sulfate build-up on the battery plates, and is used only on flooded lead acid batteries. Refer to the battery manufacturer for frequency recommendations.

### **WARNING: DO NOT USE WITH SEALED OR LEAD CALCIUM MAINTENANCE FREE BATTERIES.**

The Equalization Charge Cycle is initiated by switching Program Switch 3 from OFF to the ON position. The Equalize Cycle is automatically terminated after 1 hour. The Equalize Cycle will be manually terminated by turning the Program Switch 3 to the OFF position or by turning the Main ON/OFF Switch OFF or by turning shore power OFF.

**Figure 5 Battery Charging Graph**

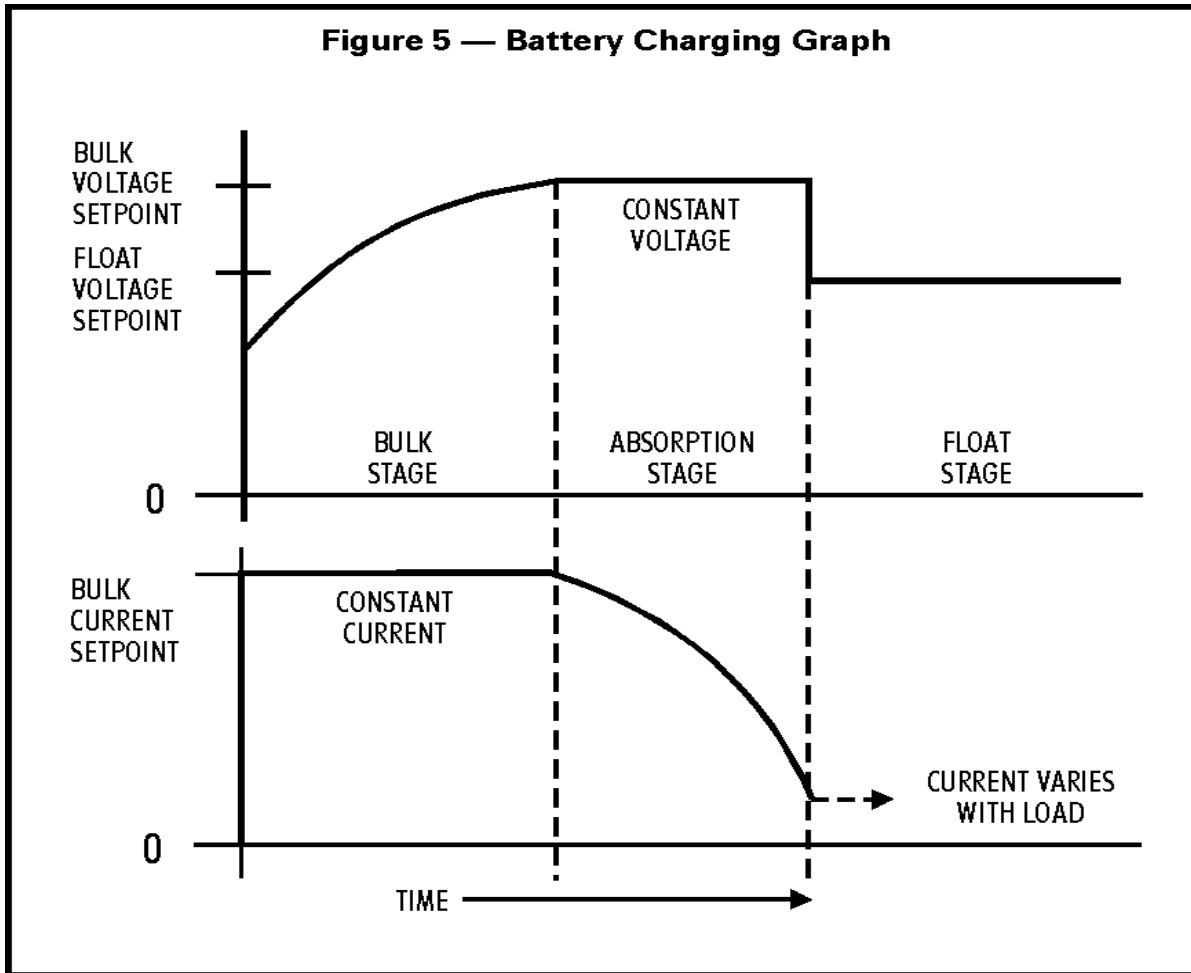

### 5.3 Automatic Power Transfer Switch Theory of Operation

The function of the Automatic Transfer Switch is to automatically accept AC input power from shore or generator, and use this power to operate inverter loads and to provide power for battery charging. Upon loss of AC input power, the transfer switch automatically switches the AC loads back to inverter power. Transfer time is approximately 30 milliseconds (0.030 seconds). The 0.030 second transfer time allows all but the most sensitive loads to transfer from inverter power to shore power and back to inverter power without interruption.

AC input voltage and frequency are monitored for proper tolerance at all times on AC1. When the AC input is within tolerance for approximately 5 seconds, the power is passed through to AC3 output circuit and the IQC automatically switches from inverter mode to battery charger mode. The IQC automatically switches back to inverter mode when input power is disconnected or when input power is no longer within tolerance. See IQ Series Specifications page for AC input voltage and frequency tolerances. The 5 second delay occurs only if the inverter is fully ON when input power becomes available. There is no 5 second time delay if the inverter is in the 'Load Demand Mode' when input power becomes available.

Switch 6 on the Programming Switch allows the user to select either 90 AC input volts or 77 AC input volts to be the Low AC Input Voltage switchover tolerance value. Set switch 6 to match the quality of AC being supplied. HI (90 VAC) is generally used on more stable AC power (Residential or Industrial Supplies). LOW (77VAC) is used with less stable AC power (motor generator, solar, rural supplies).

For all IQC models, the factor that determines whether the unit is in 'inverter mode' or 'battery charger mode' is the presence or absence of 'in-tolerance' input power. Whenever 'in-tolerance' input power becomes available the IQC automatically switches from inverter mode to charger mode.

The transfer switch switches both hot and neutral. For safety purposes the inverter output neutral (terminal #8) is connected to the inverter chassis ground only when the unit is in inverter mode. This is a requirement of the National Electric Code for all systems of this type that neutral should be connected to ground only at the source of AC power, which is the inverter when in inverter mode. When an external AC input (shore power, generator) is available, the IQC Transfer Switch system breaks the connection between neutral and inverter chassis ground. The neutral-to-ground connection for passthrough power is then provided by the AC input source.

**Figure 6 AC Power Transfer Switch**

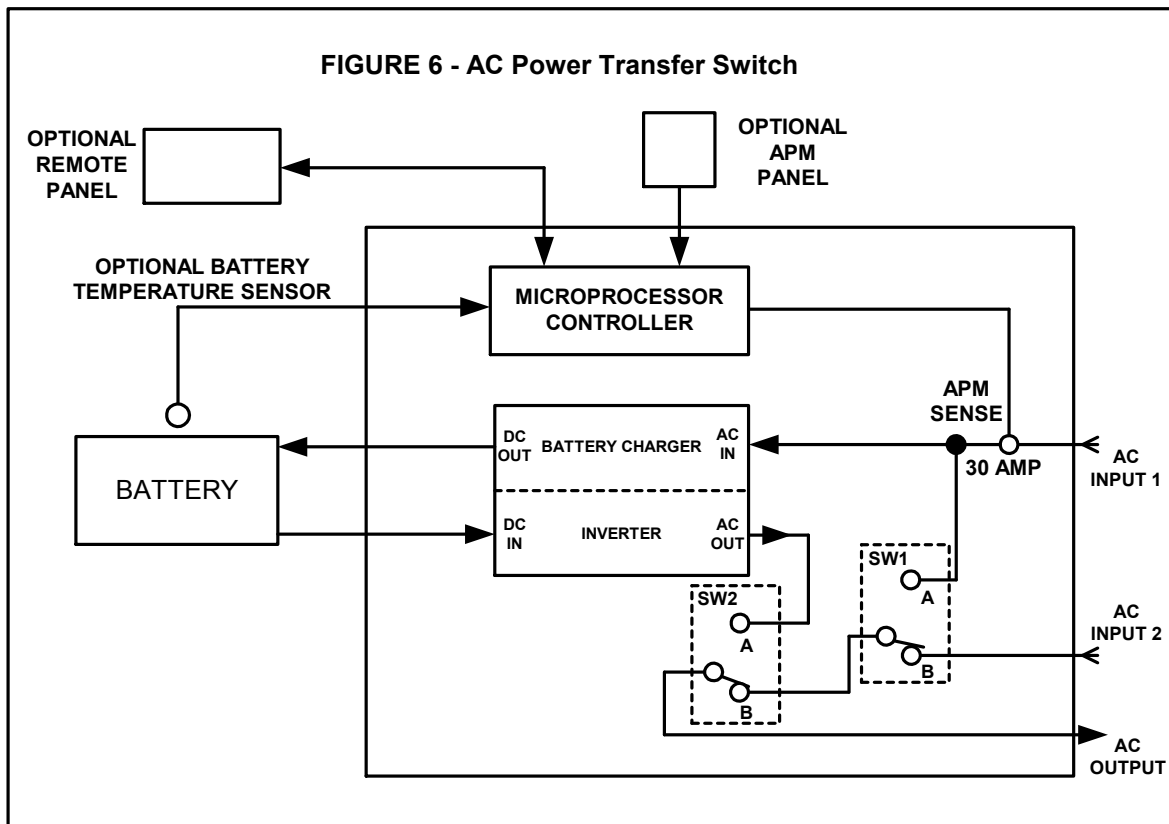



J31 is controlled by the Load Demand circuit therefore Programming Switch 2 must be in the ON position when Terminal J31 is used.

J31 is a 1/4" spade terminal located in the lower right midsection of the control circuit board. The terminal is designed to provide ground control for a Bosch relay, Vanner part number 05235 or equal. Install a 1 amp fuse in line near the inverter.

## 5.6 Ambulance Mode and Standard Mode Theory of Operation

**General:** Ambulance Mode and Standard Mode only applies to inverter/charger models.

In both modes, if the inverter is ON when shore power is applied, the charger will turn ON and will pass power through. Then, when shore power is removed, the inverter will automatically turn ON to continue to supply power to the AC loads.

In both modes, if the ON/OFF Switch is in the OFF POSITION, the system is locked OFF and neither the inverter nor the charger will operate, even if the Remote Switch is turned ON.

**Standard Mode:** The inverter and the charger functions are controlled together by the ON/OFF Switch. The system will only operate like a UPS (Uninterruptable Power Supply).

When shore power is applied while the inverter is OFF, the charger will remain OFF. The ON/OFF Switch, or Remote Switch, must be pushed to the START position to start the charger, which also allows the inverter to come ON automatically when shore power is removed.

**Ambulance Mode:** (It is common in these applications for the shore power cord to accidentally become unplugged. If the inverter were in Standard Mode and the shore power became unplugged, the inverter would automatically come on and the vehicle batteries would be run down. Ambulance Mode is offered to prevent this.)

Intended for ambulance and fire truck applications, in Ambulance Mode the inverter will remain OFF when shore power is removed even if the inverter was ON when shore power was connected. The system will not operate like a UPS. After shore power is removed, the ON/OFF Switch, or Remote Switch, must be pushed to the START POSITION to start the inverter.

As long as the ON/OFF Switch and Remote Switch are in the RUN POSITION, the charger will turn ON when shore power is applied.

**How to select Ambulance Mode:** Selection is accomplished by relocating the two-pin jumper found on terminal J3 on the LED Display Circuit Board. The factory position of the jumper is over only one pin for Standard Mode. To select Ambulance Mode place the jumper over both pins. See Figure 1 (below).

Turn the inverter OFF. Remove the front cover of the inverter to gain access to the LED circuit board located at the front of the inverter. Terminal J3 is a two-pin terminal identified on the circuit board and located approximately 1" above the yellow bulk charge indicator light. The factory position of the jumper is outlined on the board over only one pin for Standard Mode.

To select Ambulance Mode remove the jumper from the factory position and reinstall the jumper over both pins of terminal J3.

To reselect Standard Mode install the jumper over only one pin of terminal J3.

**Figure 1 Selecting Ambulance Mode or Standard Modes**

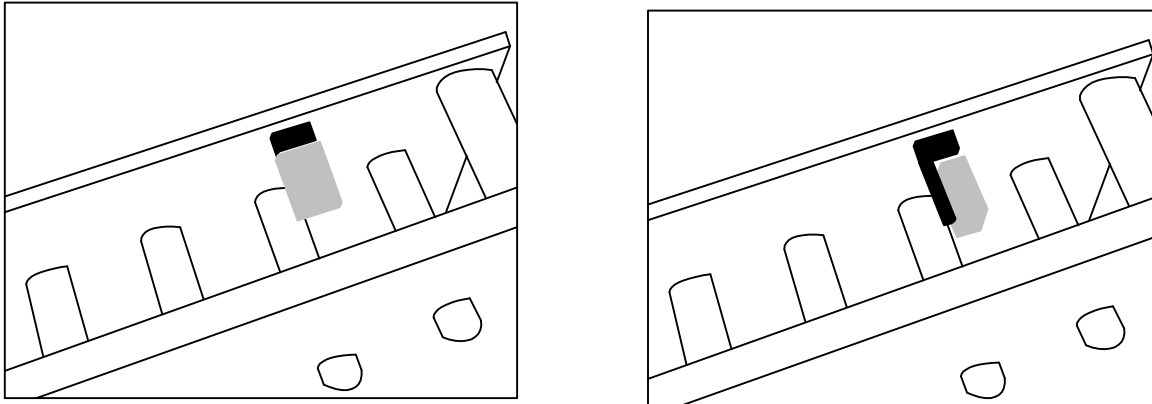

## 6 PREVENTIVE MAINTENANCE

There are no user serviceable components inside these inverters. For service refer to the Vanner Power Group or other qualified service personnel.

### 6.1 Maintenance Items

For continued reliability and safety, a monthly maintenance program should be implemented to include the following:

1. Check to insure that all DC and AC wiring connections are secure and corrosion free.
1. Check air ventilation openings for dust and other obstructions
2. Examine receptacle, indicators and switches for cracks and breaks.
3. Examine for any surfaces that are discolored or deformed due to excessive heat.

### 6.2 Troubleshooting Procedures

The following are the most common questions heard by Vanner service professionals. If your situation does not apply to the following categories, please contact your local Vanner Power Group Service Center or the Vanner Power Group Customer Service department: 1-800-AC-POWER (1-800-227-6937). Please have your model and serial number available when consulting customer service.

ALWAYS CHECK THE FOLLOWING FIRST:

- DC Fuse condition
- AC output and input breakers AC1, AC2, and AC3
- Check all GFCI breakers as equipped throughout AC system
- Unit On/Off and Remote On/Off switch positions
- Plug-in and operate an AC load from the convenience receptacle located on inverter front panel.
- Check battery connections for tightness or corrosion
- Check battery voltage at battery and inverter

Symptom	ON LED does not light steadily after pushing in the ON-OFF/RESET Inverter Switch.
Solution	Lamp flashes in Load Demand Waiting mode.

FOR IQC MODELS - Check battery connections if utility power is OFF.  
 Check DC fuses if utility power is OFF.  
 Lamp flashes when utility power is present.

Symptom Inverter LED does not illuminate  
 Solution Reset On/Off switch on unit and remote  
 Disconnect remote switch and attempt starting with unit On/Off switch  
 Check DC fuse condition

Symptom ON lamp fully illuminates. AC load does not run.  
 Solution Check and reset AC circuit breakers.  
 Check and reset any GFCI breakers in AC circuit.  
 Verify AC load and wiring are in proper condition.

Symptom BATTERY LOW lamp illuminates when AC load is applied.  
 Solution Check battery connections.  
 Check battery condition.  
 Recharge battery if voltage is less than 10.5 VDC.  
 Check the charging system for proper operation (vehicle alternator, PV array, generator).

Symptom OVER TEMP lamp illuminates.  
 Solution Something has caused the unit to overheat. Check for obstruction of air flow to the cooling fan or from ventilation holes. Verify AC load is within unit's rated capacity.

Symptom OVERLOAD lamp illuminates with AC load applied.  
 Solution Verify AC load is within unit's rated capacity.

Symptom DC fuse blows when connecting DC input cables.  
 Solution Check for reverse polarity: red cable to battery positive (+), black cable to battery negative (-) The unit may be damaged and require repair service.

Symptom Excessive audible buzzing during inverter operation but inverter operates loads.  
 Solution Check mounting bracket bolt tightness  
 Remount inverter with rubber insulator washers

Symptom AC loads do not seem to be fully energized when operating from inverter power  
 Solution Check AC output voltage at convenience receptacle.  
 Check for overheated DC or AC wiring

Symptom Unit does not operate and a "burnt wire" smell emits from inverter  
 Solution Disconnect AC loads and battery immediately  
 Unit may require service



## 7 APPENDICES

### 7.1 Inverter Overview

An inverter converts DC electrical power into AC power. This power can be used to operate various AC-driven appliances.

The most common battery systems are 12 or 24 volt. Some systems, however, operate on higher voltages such as 32, 36, 48, or 120 volts. The most common inverter AC output power is 120 volts at a frequency of 60 Hz, although some inverters are designed to produce 240 volts, or both 120 and 240 volts at 60 Hz. Because some countries use power of different voltage and frequency (e.g. 230 volts at 50 Hz), inverters are available to conform to these requirements.

Inverters use electronic circuits to switch DC input power at the required frequency, such as 60 Hz. This "switched" DC resembles AC power, and is then stepped up in voltage through a transformer. The result is a modified sine wave AC output of the required voltage and frequency that can power AC-driven equipment.

#### Inverter Types

The three available inverter types are distinguished by the type of AC output wave form they produce. This wave form affects the AC loads they operate. This section provides an overview of these inverter types, including the advantages and disadvantages associated with using each type.

##### Sine Wave Inverters

produce an AC output wave form like power produced by the electric utility companies and rotating generators. The sine wave inverter's wave form is characterized by the highest peak voltage and smooth voltage transitions (no square wave components). Such inverters are the most costly of the three inverter types because they contain extra electronics to produce the required wave form.

##### Modified Sine Wave Inverters

are sometimes called "quasi sine wave inverters" or "modified square wave inverters." Modified sine wave inverters produce an AC output wave different from the power produced by the electric utility companies and rotating generators. Although this wave form has a higher peak voltage than do square wave inverters, its peak voltage is not as high as a pure sine wave. Therefore, AC loads containing power supplies might not always operate properly on the modified sine wave inverter.

##### Square Wave Inverters

are low cost devices that produce a square wave AC power output. This AC power can be an accurate 60 Hz frequency if it is crystal controlled. It does not have the peak voltage necessary to properly operate many AC appliances that contain electronic power supplies (e.g. computers, TVs, and VCRs). The square wave is appropriate when operating AC loads such as resistive heating devices, lighting loads or universal motor loads.

### 7.2 Problem Loads

Although modified sine wave inverters will operate most AC loads, some loads may exhibit problems because the wave form is different than the pure sine wave of utility power. This is due to the square wave components and that the peak voltage is not quite as high as a pure sine wave. Loads that may exhibit problems include motor speed controls found on ceiling fans and air conditioner fans; light dimmer controls; clocks; microwave ovens (cooking time may vary and the clock may be erratic); video monitors and TVs (may have lines in the picture); AM radios (may pick a noise); laser printers; copying machines; fluorescent lights; and power supplies in some electronic devices. Rechargeable battery devices may also overheat and be damaged by the inverter. If you

desire to operate a rechargeable battery device on the inverter you should first power it up and closely observe it for a period of time to ensure that it does not run too hot.

### 7.3 Battery Types and Ratings

The batteries in general use for automotive, solar, and marine use are lead-acid storage batteries. They can be separated into two categories according to their use: engine cranking batteries and deep cycle batteries. The engine cranking battery is specifically designed to supply hundreds of amps for a short period of time to start an engine. Cranking an engine usually uses a small portion of the battery's total capacity and once the engine is running, the battery is quickly recharged by the engine's alternator. The deep cycle battery is specifically designed to deliver current for extended periods of time and can be almost totally discharged before recharging.

The "deep cycle" lead-acid battery is designed to withstand the deep discharge/recharge cycling that is typical of most inverter installations. These batteries are available in the "maintenance free" style where the electrolyte does not need to be checked or replenished and they also are available in the gelled electrolyte style or "Gel Cells". Deep cycle batteries are generally advertised for use in recreational vehicles or boats and are sometimes referred to as RV or marine batteries.

Battery Council International (BCI) is a voluntary industry organization which has helped to standardize battery ratings. Ratings in use at this date are: Cold Cranking Amperes (CCA), Marine Cranking Amperes (MCA), Reserve Capacity (RC) and Ampere-Hour (A-H). The first two of these ratings are used for sizing an engine cranking battery and have no bearing on a battery's cycling ability. Reserve Capacity is a rating given to cranking batteries to give a person some idea of how long the battery may last if the vehicle charging system were to break down and needed to continue driving the vehicle (to the nearest freeway off ramp or service station). This brings us to the oldest and probably least understood battery capacity rating, the ampere-hour. The ampere-hour is defined as follows:

#### Ampere-Hour (A-H):

A unit of measure for a battery's electrical storage capacity, obtained by multiplying the discharge current in amperes by the time in hours of discharge. The rating is usually for a discharge period of 20 hours and an end voltage of 10.5 volts. Example: A battery which delivers 5 amperes for 20 hours has a capacity of 100 A-H. (5 amperes x 20 hours = 100 Amp-Hr.)

The reason the A-H rating is misunderstood is simple. A battery that has a rating of 100 AH cannot always deliver 100 A-H. The underlying reason is the efficiency with which the battery converts its chemical energy into electric energy. The A-H capacity of a battery is affected in the following ways:

#### Discharge Rate:

A battery becomes less efficient as the discharge current increases. For example, a typical 100 A-H battery is specified to be able to deliver 5 amps for a period of 20 hours. If the discharge current were increased to 25 amps, the capacity will be reduced to approximately 75 A-H (25 amps x 3 hours = 75 A-H).

#### Operating Temperature:

A battery becomes less efficient at lower temperatures. Most battery manufacturers specify the battery A-H capacity at 80°F. At a temperature of 32°F, the same battery will have only about 65% of its rated capacity even though it may be fully charged. At a temperature of 0°F, a battery's capacity will be reduced to about 40% of its rated capacity.

#### Battery Age:

As a battery is used, some of the active material on the battery plates will deteriorate and become useless. As the battery gets older, there will be less and less useful material left on the plates and the operating time will become noticeably shorter. A battery will age faster (lose active

material from its plates faster) if it is deeply discharged regularly, if it is left in a discharged state for extended periods of time, or if it is repeatedly overcharged.

## 7.4 Inverter Sizing

Power output is an important consideration when purchasing an inverter. Power is defined as the rate that a device produces (or uses) electrical energy. This rate is measured in watts of kilowatts (one kilowatt equals 1,000 watts), or sometimes in volt-amps. Volt-amps are obtained by multiplying volts times amps produced or used by a device.

The VA (volt-ampere) rating is always equal to, or greater than the power rating of the device. The difference between the power rating and the VA rating is called the "power factor" (PF), for example: Power Rating = VA x PF. The inverter will protect itself based on the output current, and therefore must be sized to handle the VA rating of the load.

To properly determine an inverter size (in watts) for your application, decide which AC loads you plan to operate. Inverter size is the sum of the wattages of the AC loads that you wish to run at the same time, plus a safety factor of 10 to 20 percent.

### Inverter Power Ratings

Continuous Power is defined as the AC power in watts (or voltamps) an inverter can produce on a continuous basis. The ambient temperature can affect the continuous rating of the inverter, and is normally specified, e.g., 25 C.

Surge Power is the short term duration of AC power that the inverter can produce. It is often specified as the watts (or volt-amps) that can operate a resistive load for two or three seconds. Sometimes this specified in AC amps because the inverter may allow its output voltage to drop (which would reduce its wattage). Like continuous power, the surge rating is affected by ambient temperature.

The surge power that the inverter can produce is dependent on the inverter surge rating, the battery size, and state of charge.

## 7.5 DC Power Consumption

An inverter takes in DC power, and produces AC power to operate attached loads. In general, we can see a direct relationship between DC input power and AC output power. This allows us to establish the following rule:

For every 10 watts of AC output power, an inverter requires one amp of DC input power on a 12 volt input inverter.

Example:

An inverter powering a 1,000 watt AC load requires 100 amps DC at 12 volts.

$1000 \text{ watts} / 10 = 100 \text{ amps}$

Using our rule, we can determine the requirements for an electrical system needed to power our inverter (typically, an alternator and battery combination, or a photovoltaic panel and battery combination).

## 7.6 Overall System Design Considerations

To get the best performance from your inverter, it must be installed properly and have an ample DC supply. We will not be able to cover all the possible situations encountered when installing a power inverter, but we will cover

the basic information required to properly size your vehicle alternator and inverter battery, as well as give some examples of AC power distribution systems which are commonly used. Keep in mind that if information in this manual directly conflicts with instructions from a specific battery or other equipment manufacturer, you should follow that manufacturer's recommendations.

### Inverter DC Input Current Requirements

A DC to AC inverter converts DC power into AC power. For the purposes of this discussion, power (watts) is equal to the supply voltage (volts) multiplied by the current draw (amps) from the supply for both AC and DC circuits. For example, 2400 watts = 12 volts DC x 200 amps, and 2400 watts = 120 volts AC x 20 amps. From these two examples of 2400 watts at 12 volts and 2400 watts at 120 volts, it is easy to see that since there is a 1 to 10 voltage conversion (12 to 120), there is a 10 to 1 amp conversion (200 to 20). A more accurate relationship between the input power and output power is:

$$(\text{DC Input Power}) \times (\text{Efficiency}) = (\text{AC Output Power})$$

This formal relationship has lead to the following rule of thumb for estimating the DC input amps for an inverter:

For 12 volt DC inverters: output watts  $\div$  10 = DC input current

For 24 volt DC inverters: output watts  $\div$  20 = DC input current

This rule of thumb can be used to estimate the minimum alternator size required for your application and is also used later in calculating the minimum size battery required when operating from battery only. The following examples should help to clarify the use of this rule of thumb.

#### Example A:

What is the DC current draw of a 12 volt DC input inverter when it is operating a vacuum cleaner with a name plate rating of 6 amps at 120 volts AC?

The appliance rating is given in amperes, so we must first calculate the power it consumes. Then the rule of thumb can be used to find the DC input current of the inverter.

Output power = 120 volts x 6 amps = 720 watts, and DC input current = 720  $\div$  10 = 72 amps DC.

#### Example B:

What is the DC current draw of a 24 volt DC input inverter when it is operating a toaster with a name plate rating of 1050 watts at 120 volts AC?

Since the appliance is rated in watts, the rule of thumb can be applied directly:

DC input current = 1050  $\div$  20 = 52.5 amps DC.

This information on estimating the DC input current requirement for an inverter will allow you to size an alternator or charging system to supply an inverter for continuous operation.

### Sizing the Inverter Battery

Sizing a battery system for an inverter application can be a very tedious task if all the different variables, such as discharge rate, depth of discharge, and operating life time are included in the calculations. To simplify these calculations and get a reasonably correct battery size, we will assume: 1) A 50% depth of discharge for the purpose of obtaining a reasonable life time for a reasonable battery system cost, 2) there is no charge current into the battery system, 3) the batteries are in a fully charged state at the beginning of the discharge cycle, and 4) the DC current draw from the battery does not exceed 1/3 the battery C rate for any length of time.

Follow the steps listed below to find the A-H capacity required for your application.

#### Steps

1. Make a list of each appliance, its power requirement in watts, and the amount of time in hours it will be operating between charging cycles.

2. Calculate the watt-hours required for each appliance by multiplying the power requirement by the operating time of that appliance.
3. Calculate the total watt-hours needed by adding together the watt-hours of each appliance.
4. Find the amp-hours consumed by dividing the total watt-hours found in step 3 by 10 for 12 volt DC systems or by 20 for 24 volt DC systems.
5. Multiply the amp-hours consumed by 2 (for 50% depth of discharge) to get the battery amp-hour capacity desired.

### DC Charging Systems

The DC charging system is a very important part of your inverter installation. The system consists of the primary charger (engine alternator or photovoltaic array), a secondary charger, if used, the battery, and other equipment which may be used such as battery isolator diodes. The complexity of the system depends on the way the inverter is used. In some cases, such as utility or service vehicles, the system may be as simple as the engine alternator and the cranking battery which also powers the inverter. In most cases, additional equipment is needed to provide additional DC power and/or protection. These systems can be grouped into two categories, the single battery and the dual battery systems.

In the single battery system, there is one battery which is shared for starting the engine and operating the inverter. This is a common practice in a service vehicle where the engine runs all the time and allows the alternator to provide continuous charging for the battery. In this case, the inverter's auxiliary batteries can be connected directly to the engine cranking battery. Great care should be used when operating this type of system. If the engine were to be shut off and the inverter operated, it would not take a very long time for the inverter to discharge the cranking battery and disable the vehicle! The most important detail of this system is the alternator output rating. The continuous output of the alternator needs to be at least as much as the total DC current draw on the system. The total DC current draw must include the inverter, warning lights, radios, engine controls, and any other device connected to the DC system.

The dual battery system uses two separate batteries, one for starting the engine and operating the vehicle's systems, and one for operating the inverter. The two batteries are usually referred to as the "cranking battery" and the "house battery" respectively. The two separate batteries are usually charged from the same source, the engine alternator, but are separated by a device called a battery isolator. The battery isolator allows DC current to flow from the alternator into each battery, but blocks current from flowing from one battery to the other. This is a must to protect the cranking battery in recreation vehicles, boats and other vehicles where the inverter needs to be operated when the engine (therefore the alternator) is not running.

Up to this point we have spoken of the battery as if it were a single battery. In some cases this may be true, but in general, the battery may be made up of several individual batteries electrically connected together to form a "Bank" of batteries. Batteries can be connected in series, parallel, or a combination of series and parallel as long as all of the batteries in the bank are of equal ratings, are from the same manufacturer, and are the same age. Old and new batteries should never be mixed in the same battery bank. A series connection is where two or more batteries are connected positive (+) to negative (-) and the total voltage of the battery bank is the sum of the voltage of each battery in the bank. For example, most large custom coaches require a 24 volt battery to crank the large diesel engine. The 24 volts is usually provided by connecting two 12 volt batteries in series, and sometimes by connecting four 6 volt batteries in series. The ratings of the series connected battery bank remain the same as the individual battery's rating. If the battery bank is made up of two 8D size batteries in series, each with a CCA of 1050 amps, 425 minutes RC, and amp-hour capacity of 200 A-H, then these individual battery ratings are also the ratings of the entire 24 volt battery bank. This unit is considered a 200 A-H battery system, but running at 24 volts.



**8 North American Warranty**

---

**NORTH AMERICAN LIMITED WARRANTY**

---

Vanner Inc. doing business as The Vanner Power Group, referred to herein as Vanner, warrants that this product is free from defects in materials and workmanship for a period of one (1) year from date of installation or one and one half (1-1/2) years from date of manufacture, whichever is less if and only if the following requirement is complied with:

1. The product is installed and checked out properly according to all guidelines, instructions, and checkout procedures set forth in the product Installation and Operating Manual.
2. The installer records all checkout data required and completes, signs, and returns the warranty registration card to Vanner within ten (10) days after installation.

Vanner does not warrant its products against any and all defects when; Defect is a result of material or workmanship not provided by Vanner; normal wear and tear, or defects caused by misuse or use in contrary to instructions supplied, neglect, accident, reversed polarity, unauthorized repairs and/or replacements.

All warranties of merchantability and fitness for a particular purpose: written or oral, expressed or implied, shall extend only for a period of one (1) year from date of installation or one and one half (1-1/2) years from date of manufacture, whichever is first. There are no other warranties which extend beyond those described on the face of this warranty. Some states do not allow limitation on how long an implied warranty lasts, so the above limitations may not apply to you.

Vanner does not undertake responsibility to any purchaser of its product for any undertaking, representation, or warranty made by any dealers or distributors selling its products beyond those herein expressed unless expressed in writing by an officer of Vanner.

Vanner does not assume responsibility for incidental or consequential damages, including, but not limited to responsibility for loss of use of this product, removal or replacement labor, loss of time, inconvenience, expense for telephone calls, shipping expense, loss or damage to property, or loss of revenue. Some states do not allow the exclusion or limitation of incidental or consequential damages, so these limitations may not apply to you.

Vanner reserves the right to repair, replace, or allow credit for any material returned under this warranty. Any damage caused by the customer will be charged or deducted from the allowance.

All warranty work will be performed at Vanner's factory, or authorized repair facility utilizing a valid Warranty Authorization Number (WAN) prior to repair. Products shall be delivered to Vanner's facility, freight prepaid and fully insured. Products repaired under warranty, or replacement parts or products will be returned to North American location prepaid via same transportation means and level of service as received, unless directed otherwise. Prepaid freight policy does not apply to locations outside North America.



**Vanner Incorporated  
4282 Reynolds Drive  
Hilliard, Ohio 43026**

**1-800-AC POWER  
(1-800-227-6937)  
Tel: 614-771-2718  
Fax: 614-771-4904**

**www.vanner.com  
e-mail: [pwrsales@vanner.com](mailto:pwrsales@vanner.com)**

**Manual Part Number D97854-D  
Printed in USA**