



5860GCPE FLASHER Owner's Manual

GENERAL

The 5860GCPE electronic flasher has been designed to operate in the most severe environments. This heavy duty flasher has been designed and certified to Federal specification for Ambulances KKK Standards. The flasher has output short circuit protection and reverse input voltage protection. This unit is designed to be operated manually in either the Primary or Secondary mode. Primary Mode is standard running mode, which alternately flashes the A warning lights with the B & C warning lights. The Secondary Mode is normally used at the scene and alternately flashes the A warning lights with the B warning lights, with C lights off. All lamps operate at full power when in either mode.

WARNING LIGHTS

The 5860GCPE flasher can be used with most incandescent, halogen, and LED warning lights.

CHARACTERISTICS & TIPS

- 1) For extended service reliability, it is important that the flasher is not overloaded. In some cases the unit's short circuit protection may consider the overload a short circuit, and shut the unit down.
- 2) If the Primary and Secondary terminals are both grounded, the flasher will operate in Primary Mode.

SPECIFICATIONS

Maximum output current:	Terminal A: 60 Amps Terminal B: 40 Amps Terminal C: 40 Amps
Input Voltage:	10-16 Vdc, 13.6 Vdc nominal
Flash Rate:	75-80 per minute at 50% duty cycle
Ambient temperature:	-40°F to +122°F (-40°C to +50°C)
Fuse or Circuit Breaker	70 Amps max. Customer supplied overload protection <u>must</u> be in series with +12Vdc input, and should be 25% greater than either all A lights, or all B & C lights, whichever is larger.

TROUBLESHOOTING

PROBLEM	ITEMS TO CHECK
All outputs do not flash:	<ol style="list-style-type: none"> 1) Is the battery voltage less than 10Vdc? 2) Are the wire and light connections proper? 3) Do you have more than the rated number of lights on the outputs? 4) Is the remote ground switch wired correctly?
One output does not flash:	<ol style="list-style-type: none"> 1) Is the battery voltage less than 10 Vdc? 2) Is the affected output shorted or overloaded? 3) Are the wire and light connections proper?

***If after reviewing this chart you still can't locate the problem, contact Vanner for technical assistance - 800-AC-POWER.**

LAMP PLACEMENT DIAGRAM

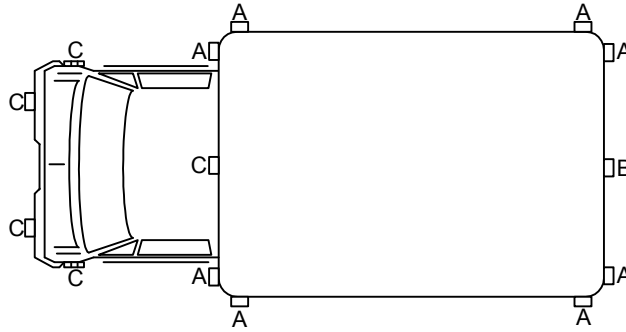

OPTIONAL PLACEMENT

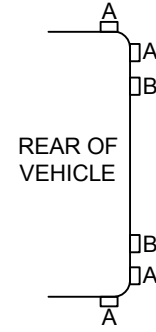

CONNECTION DIAGRAM

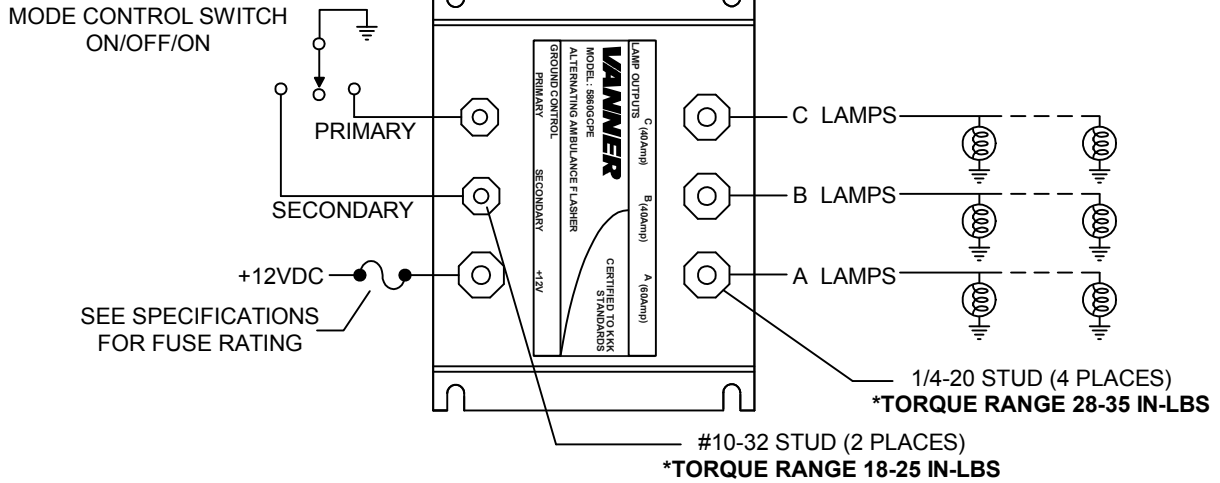

*CAUTION

THE STUDS (TERMINALS) ON THE 5860GCPE FLASHER ARE SOLDERED TO THE INTERNAL PRINTED CIRCUIT BOARD. OVER TORQUING WILL DAMAGE THE PRINTED CIRCUIT BOARD.

MOUNTING DIMENSIONS

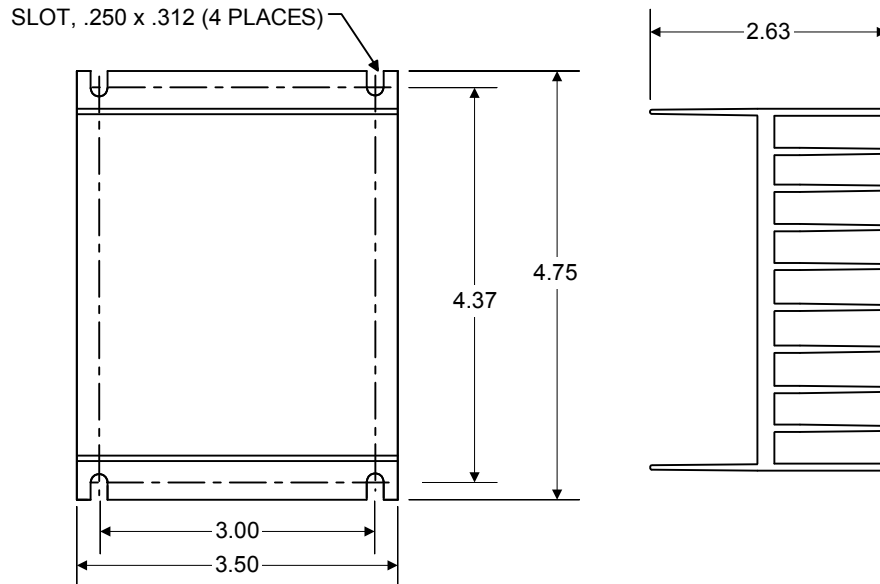

VANNER INC.

800-AC-POWER