

VoltMaster Battery Equalizer

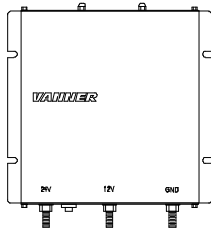

Family 1
60-10B
60-20A
60-50A
60-50E
60-50M

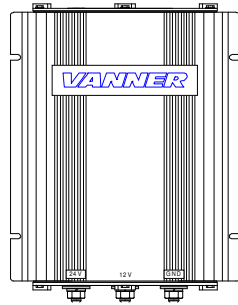

Family 2
60-100C
60-100D
60-100E

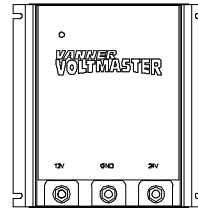

Family 3
60-60
60-60M
60-80
60-100

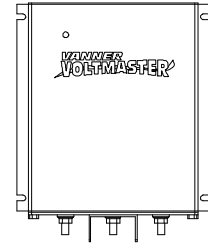

<u>Family 4</u>	<u>Family 5</u>
65-60	66-60
65-60M	66-80
65-80	66-100
65-100	

Table of Contents

Introduction.....	2
Specifications.....	3
Theory of Operation.....	4
Typical Applications.....	5
Installation Instructions.....	7
Testing and Troubleshooting.....	9
Warranty.....	15

Introduction

Thank you for purchasing a Vanner *VoltMaster* Battery Equalizer. We are confident that you will be very pleased with its performance because our Battery Equalizers are designed and manufactured by skilled professionals using the highest standards in workmanship. With minimum maintenance and care, you can be assured of many years of trouble free service.

General Description

The Vanner *VoltMaster* Battery Equalizer is an efficient and highly reliable method of obtaining a 12 volt DC power source from a 24 volt DC electrical system. The equalizer makes the batteries look like they are in series and parallel at the same time. In addition to providing regulated 12 volt power, the system ensures that battery voltages remain equal which significantly extends battery life. Ideally suited for vehicle and alternate energy applications, the *VoltMaster* Battery Equalizer is designed to save your batteries and the money you would spend replacing them. Users of the Vanner *VoltMaster* Battery Equalizer know that it is the most cost effective and dependable solution for dual voltage systems.

A typical system would include a 24VDC power source, such as an alternator or solar array, two 12 volt battery banks in series, and the *VoltMaster* Battery Equalizer. The Battery Equalizer connects to the 24 volt, 12 volt and ground terminals of the battery system. When the 12 volt loads require power, the Battery Equalizer ensures that the current is taken equally from both batteries, and that the voltages of the two batteries are kept equal. This equalization ensures extended battery life and provides a stable 12 volt supply for operating accessories.

Parallel Equalizers: Models are available which provide 10, 20, 60, 80 and 100 amps of 12 volt DC power. *VoltMaster* Battery Equalizers may also be operated in parallel to provide more power. For example, two 60 amp units can be installed to provide 120 amps of 12 volt DC power. Family 1, Family 3, Family 4, and Family 5 models may be paralleled in any combination. Family 2 models may be paralleled only with other Family 2 models.

NOTE: The Vanner *VoltMaster* Battery Equalizer is an extremely reliable device and, when installed according to the instructions, will provide reliable operation for an indefinite period of time. However, if a system abnormality should develop that would cause a Battery Equalizer malfunction, damage to the battery system could result if 12 volt loads are present. If your system application is critical you may consider installing a Vanner **Model EM-70 Electrical System Monitor**. This module monitors the battery system's voltages and balance, and provides fault signals that can be wired to warning lights, buzzers or other control/warning devices. Models 60-50M , 60-60M and 65-60M have the EM-70 built in. Call Vanner for more details.

Specifications

Model Number	Family 1			Family 2*	Family 3* / Family 4			Family 5		
	60-10B	60-20A	60-50A*	60-100E*	60-60*	60-80*	60-100*	66-60	66-80	66-100
Input Voltage 24v	20 to 35v			18 to 36v	18 to 32v			18 to 32 v		
Efficiency (Peak)	>91%	>92%	>92%	>94%	>97.5%	>97.5%	>97.5%	>97%	>97%	>97%
Max 24v Input Amps	6	12	28	55	32	43	53	32	43	53
Output Voltage	(Input Voltage/2) ±2% - 50mv									
Output Amps (12v)	0-10	0-20	0-50	0-100	0-60	0-80	0-100	0-60	0-80	0-100
Standby Current	17 milliamps nominal at 28.4V									
Operating Temp.	-40°C to +71°C (-40°F to 160°F)				-40°C to +75°C (-40°F to 167°F)					
Storage Temp.	-54°C to +85°C (-65°F to 185°F)				-54°C to +95°C (-65°F to 203°F)					
Serviceable	Yes	Yes	Yes	Yes	No	No	No	No	No	No
Environmental Considerations	Anodized aluminum enclosure provides protection against salt, fungus, dust, water, fuel vapors and all fluids associated with commercial and off-highway vehicle operations. Continuous exposure to splashes and spills should be avoided.									
Mounting Location	Mount on a flat surface close to the batteries to allow short cable runs. Vertical mounting with terminals down is recommended. Location should be protected from battery acid and gases.									
Weights	2.3 lbs	5.0 lbs	7.0 lbs	9.5 lbs	6.0 lbs	6.6 lbs	6.6 lbs	6.0 lbs	6.3 lbs	6.3 lbs
					7.0 lbs	7.6 lbs	7.6 lbs			

Unlisted models: Model 60-60M and 65-60M have built-in EM-70 Electrical System Voltage Monitor. Model 60-50M is a 60-50A with built-in EM-70. Model 60-50E is a 60-50A with weather resistant gasket. Model 60-100C is an early 60-100E. Model 60-100D is a 60-100C with circuit breakers instead of internal fuses. Older models not listed in the above table should be tested as Family 1 and should be considered non-repairable.

*Obsolete.

Family 1 and Family 2 Equalizer Dimensions

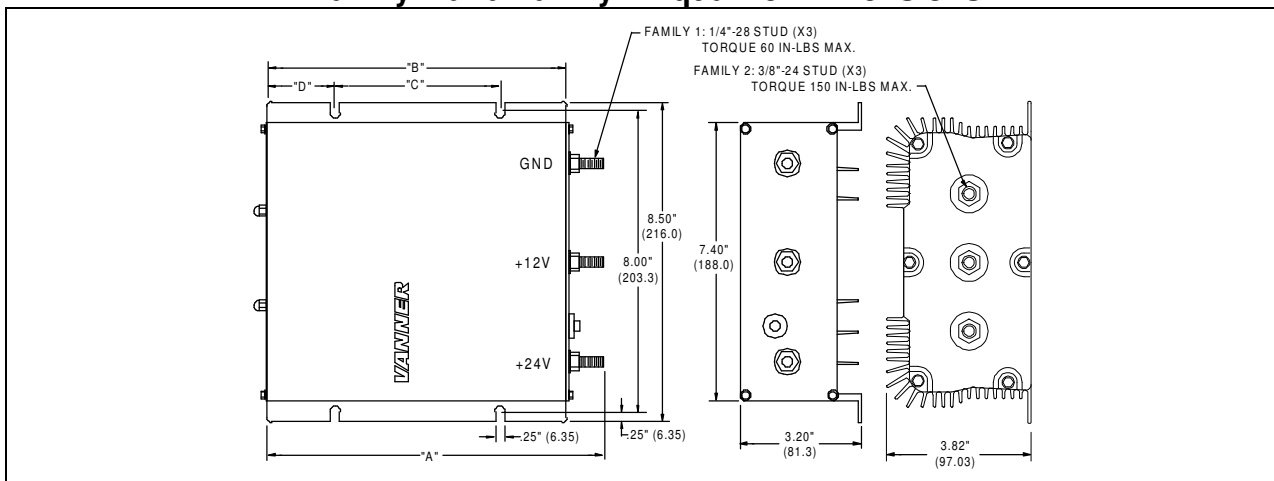

Model	"A"	"B"	"C"	"D"
60-10B	4.25 (107.9)	3.00 (76.3)	2.00 (50.80)	0.50 (12.7)
60-20A	9.38 (238.2)	8.00 (203.2)	4.50 (114.3)	1.75 (44.4)
60-50A	13.38 (339.8)	12.00 (304.8)	8.00 (203.2)	2.00 (50.8)
60-100C	13.46 (341.88)	12.00 (304.8)	8.00 (203.2)	2.00 (50.8)

Family 3 Equalizer Dimensions

Family 4 and Family 5 Dimensions

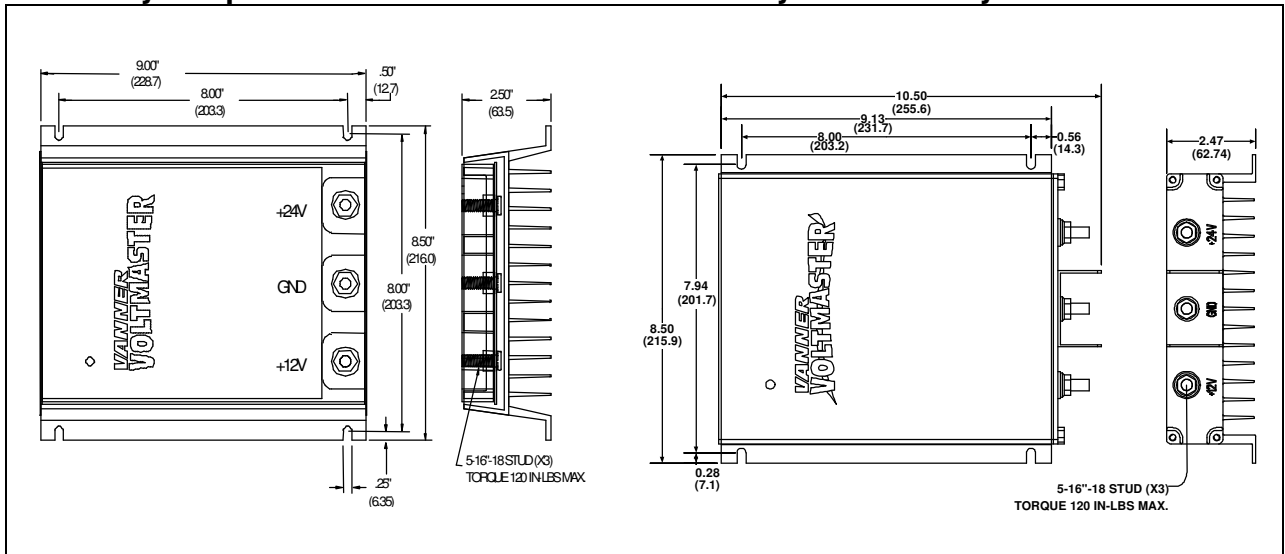

Theory of Operation

In many 24 volt electrical systems it is desirable to tap into the battery system to obtain power for 12 volt loads. This method, while seemingly simple, causes a charge imbalance resulting in Battery B (see diagram) being overcharged, and possibly boiling, while Battery A discharges.

To solve this application problem the Vanner *VoltMaster* Battery Equalizer is connected to the battery system at the +24 volt, +12 volt, and ground points. The Battery Equalizer makes the batteries look like they are in series and in parallel at the same time. The Battery Equalizer maintains the voltage balance and therefore the charge acceptance rate of each battery. Family 3 and Family 4 Equalizers hold Battery A and B voltages to within 0.05 volts under light loads and to within 0.1 volts at full rated load. Family 1 and Family 2 models hold Battery A and B voltages to within 0.10 volts under light loads and to within 0.50 volts under full rated load.

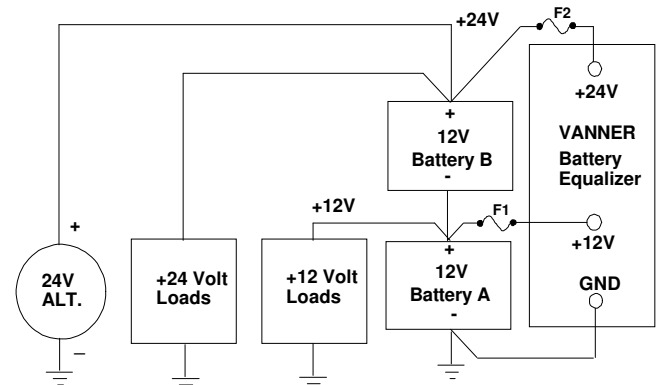

Note-Battery Banks A and B should have the same amp-hour capacity.

When the voltage of Battery A is higher than or equal to Battery B the Battery Equalizer is in the standby mode, i.e., it is not transferring power from its 24 volt input to its 12 volt output. When a 12 volt load is present, and Battery A's voltage decreases to just below the voltage of Battery B, the Battery Equalizer activates and transfers sufficient current from Battery B to Battery A to satisfy the load and maintain an equal voltage and charge in both batteries.

A key advantage of a system containing a Vanner *VoltMaster* Battery Equalizer, compared to a DC to DC converter, is that if the 12 volt load requires a momentary surge current which exceeds the rated capacity

of the Battery Equalizer, Battery A will supply the extra current to the load. The Battery Equalizer will then replenish the energy to Battery A after the surge has passed.

The *VoltMaster* Battery Equalizer is a completely automatic device that requires no human intervention when installed according to the recommended procedures. Family 1 Equalizers and some Family 2 Equalizers have a manually resettable circuit breaker. If the circuit breaker trips, due to a system overload or abnormality, it can be reset by pushing the white button. Note that on some units the white circuit breaker button may protrude slightly in its normal (non-tripped) position. A blown fuse on Family 2 Equalizers requires factory repair. There are no user operational devices on Family 3, Family 4 or Family 5 models.

The following scenarios describe the *VoltMaster* Battery Equalizer's system operation.

Scenario #1 - 24 volt load present, no 12 volt load present. The system operates as a system would without the Battery Equalizer whether the alternator is ON or OFF. The Battery Equalizer is in the standby mode except for making small adjustments to keep the batteries in balance.

Scenario #2 - Both 24 volt and 12 volt loads present, alternator is OFF. The Battery Equalizer will insure that both batteries will discharge at the same rate even if different loads are present.

Scenario #3 - Both 24 volt and 12 volt loads present, alternator is ON. The alternator provides 24 volt power to the battery system and to the 24 volt loads. The Battery Equalizer transfers power from the 24 volt source to the 12 volt load by converting 24 volt power to 12 volts. It will supply sufficient 12 volt power to satisfy the 12 volt load and to maintain battery voltage balance.

Typical Applications

Vanner *VoltMaster* Battery Equalizer are used in many types of applications including transit and tour buses, private coaches, heavy trucks and off highway equipment, yachts, and alternative energy systems such as solar powered homes. In addition to Battery Equalizers, Vanner manufactures a wide range of complementary products such as DC to DC converters, DC to AC inverters, battery charger/conditioners, and battery isolators. The following system diagrams illustrate how these products are used in various applications.

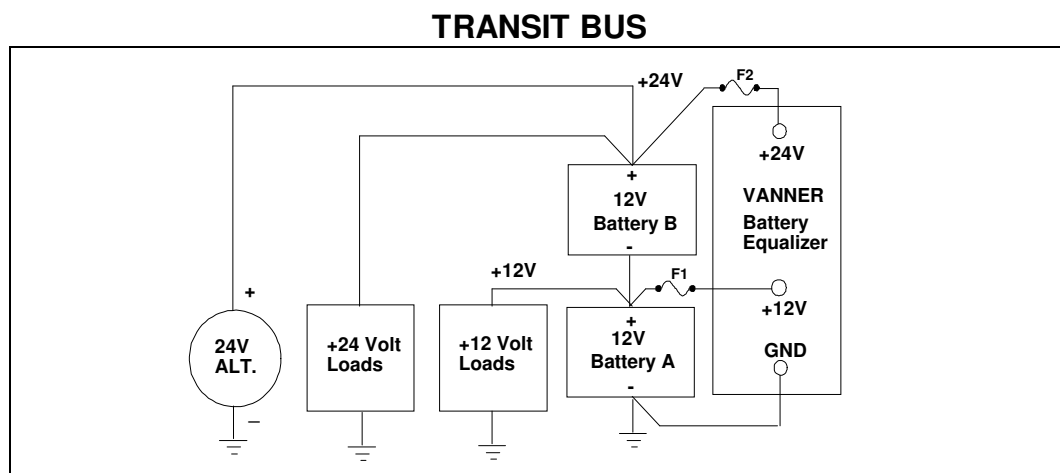

PRIVATE COACH

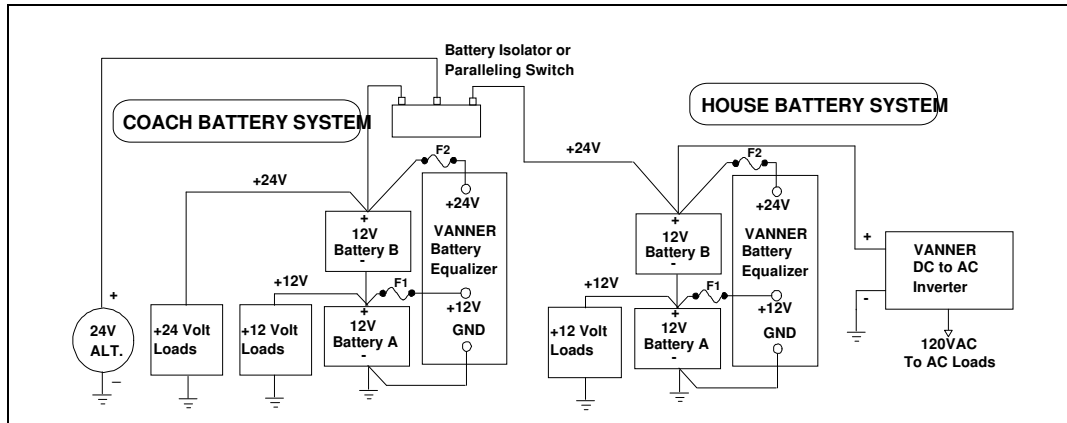

TOUR/CHARTER COACH

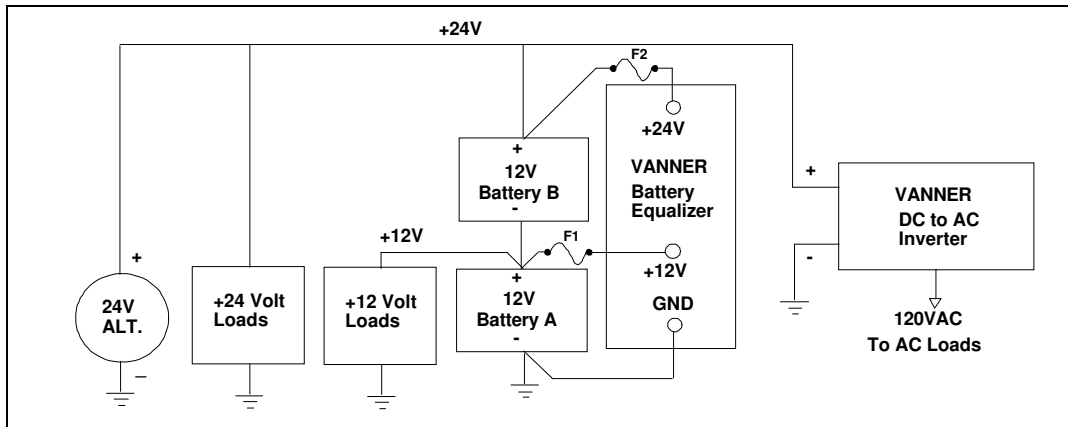

MARINE

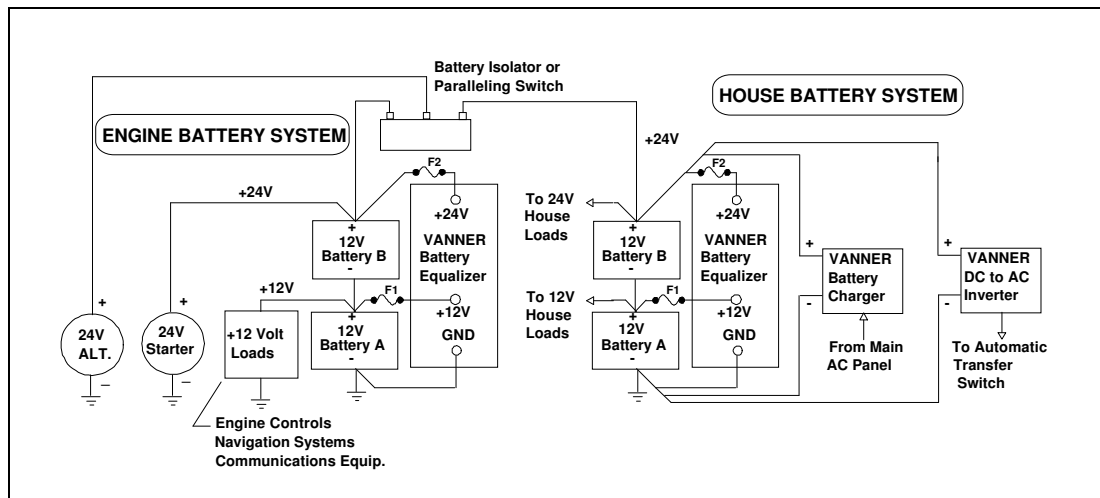

Installation Instructions

When connecting wires or cables to the available post (+24, GND, +12) when installing Vanner Equalizer Models 60-60, 60-80, 60-100, do not exceed the specified torque of 120 in-lbs. This information is printed on the Product Label just above the connection post. Torque values higher than specified may damage the product, reducing performance or creating hazardous conditions. Products damaged by improper torque may not be covered by warranty.

Do not connect more than one conductor per available post on any model of Vanner Equalizer. Multiple wires and cables may overstress internal components, resulting in poor performance or creating hazardous conditions. Products damaged by the installation of multiple conductors per post may not be covered by warranty.

Fault protection devices must be installed between the Equalizer and the power source (battery). A fault protection device would be any fuse or circuit breaker properly rated for the maximum DC current obtainable. This advisory is in accordance with SAE, NEC and UL, for mobile power applications. Install per applicable codes or within 18" of the battery. See Wire and Fuse Sizing Chart on page 9 of this manual or contact Vanner at 1-800-227-6937 or pwrsales@vanner.com if assistance is needed in sizing fault protection devices.

Caution: This equipment employs components that tend to produce arcs and sparks. To prevent fire or explosion, do not install in compartments containing batteries or flammable materials. Safety goggles should always be worn when working near batteries

Mounting Location –The Equalizer may be mounted in any orientation, however, the recommended orientation for optimum heat dissipation is vertical. It is recommended that the wiring terminals be down to prevent the possibility of a falling metal object shorting the terminals. Do not mount in zero-clearance compartment that may result in the Equalizer overheating. Locate so that contact by people is unlikely.

Environmental Protection – Do not expose to rain or moisture. The unit should be located in an area that will protect it from direct exposure to moisture such as high pressure washing, rain, etc.

Wiring Sequence– To prevent reverse polarity damage on Family 1 and Family 2 models when connecting/disconnecting battery terminals: ALWAYS 1) Remove Equalizer ground terminal first, and 2) Replace Equalizer ground terminal last. The wiring sequence is not an issue with Family 3 or 4 models.

Equalizer Models 60-50M, 60-60M and 65-60M with built-in EM-70 Battery Monitor

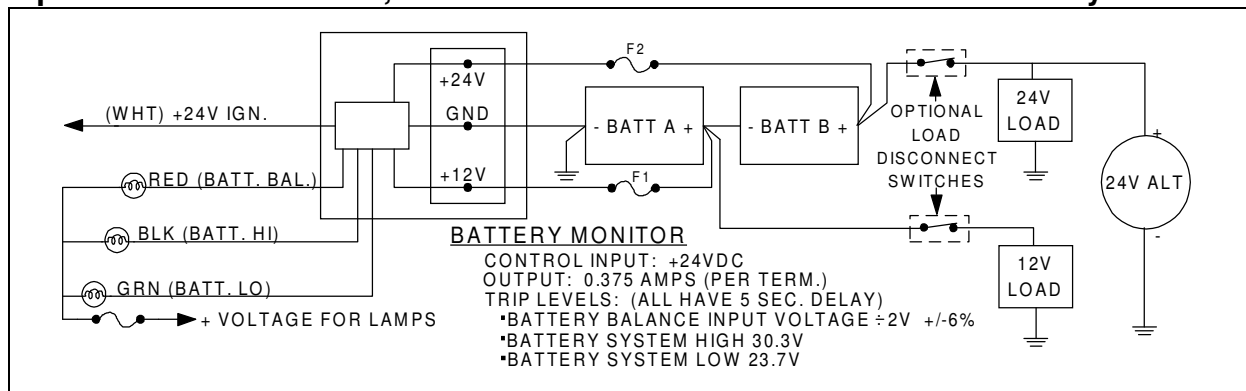

The EM-70 Battery Monitor provides the following ground signals: Battery HI when +24 rises above 30.3V, Battery LO when +24 falls below 23.7V, Battery BALANCE when +12 is not within 6% of $(+24 \div 2)$. Each ground signal is rated 0.375 amps and should be protected by a 1 amp fuse.

Caution adding 12volt batteries

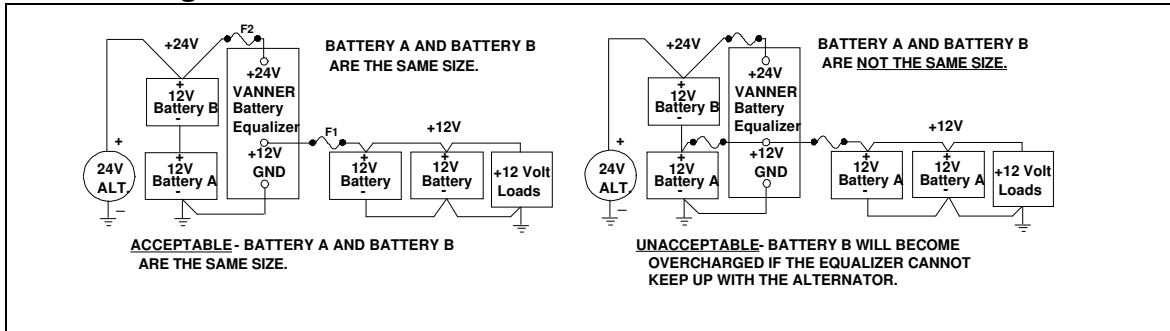

In certain applications, such as private coach or alternate energy applications, it may be desirable to have additional 12 volt “House Batteries” to operate heavy 12 volt (inverter) loads. Use the Equalizer to charge the additional batteries.

Connect the Equalizer 12V terminal to the additional batteries only. Do not connect the Equalizer 12V terminal to both battery banks as this would make Battery A larger than Battery B. **Damage to Battery B may occur during charging** due to overcharging, if the equalizer cannot keep up with the charging system.

Caution using a Ground-Side Battery Disconnect Switch

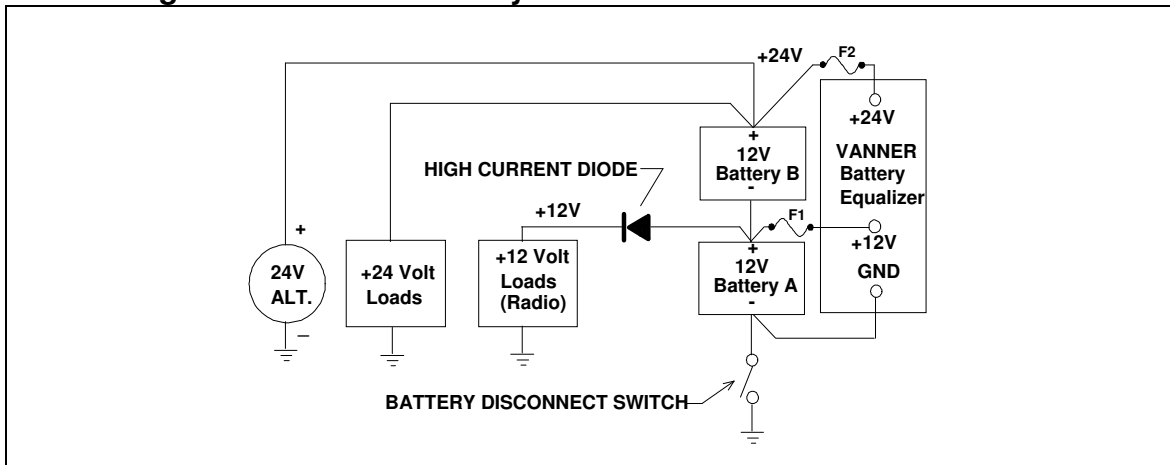

The system must be wired as shown to prevent Reverse Polarity Damage to polarity sensitive 12 volt loads and Family 1 and Family 2 Equalizers while the ground-side disconnect switch is open. The equalizer's GND terminal must be wired to the battery side of the ground-side disconnect switch circuit for the equalizer to work properly.

Install the external High Current Diode, such as Vanner Model 52-75 (45 amp continuous rating) to protect polarity sensitive 12 volt loads if these loads do not already contain input diode protection. This prevents a reverse polarity on the 12 volt equipment when the battery switch is open. The reverse polarity does not come from the Equalizer but from any 24 volt equipment that may be turned ON.

Wire Size and temperature rating

Cables connecting the Battery Equalizer to the batteries must be sufficiently large to prevent unwanted voltage drops. These voltage drops (loss) must be less than 0.05 VDC between the Equalizer's +24 volt terminal and the battery +24 volt terminal (Battery B positive terminal), less than 0.10 VDC between the Equalizer's +12 volt terminal and the battery +12 volt terminal (the jumper between Battery A and Battery

B), and less than 0.05 VDC between the Equalizer' sGND terminal and the battery ground terminal (Battery A negative terminal that is connected to chassis ground). In most installations, the Battery Equalizer' s terminals are wired directly to the battery terminals to prevent voltage loss that could occur in switch contacts, connections, and long wire runs. Since the equalizer can be operated in temperatures up to 71° or 75° C, use wire rated at least 90° C. See Wire and Fuse Size Chart.

Wire and Fuse Size Chart

Wire Size AWG	Ring Terminal Molex or UL recognized equal	Max wire length, in feet, between Equalizer and battery to keep voltage drop under 0.1 volt. The chart assumes wire carries no other load and wire temperature is below 80° C.						
		60-10	60-20	60-50	60-60	60-80	60-100	2 x 60-100
					65-60	65-80	65-100	2 X 65-100
#14	191930072	3.2	XXX	XXX	XXX	XXX	XXX	XXX
#12	191930134	5.0	2.5	XXX	XXX	XXX	XXX	XXX
#10	191930134	7.7	3.8	XXX	XXX	XXX	XXX	XXX
#8	191930157	12.8	6.4	2.6	2.1	XXX	XXX	XXX
#6	191930251	19.4	9.7	3.9	3.2	2.4	XXX	XXX
#4	191930278	35.2	17.6	7.0	5.9	4.4	3.5	XXX
#2	191930309	51.9	26.0	10.4	8.7	6.5	5.2	2.6
#1	191930333	65.4	32.7	13.1	10.9	8.2	6.5	3.3
#1/0	191930333	82.9	41.4	16.6	13.8	10.4	8.3	4.1
#2/0	191930346	105.5	52.7	21.1	17.6	13.2	10.5	5.3
Fuse F1		20 amp	30 amp	80 amp	80 amp	100 amp	125 amp	250 amp
Fuse F2		10 amp	15 amp	35 amp	40 amp	50 amp	80 amp	150 amp

Crimp the ring terminals using *Molex* tool 192840002 (14ga), 192840001 (10 -12ga), 192840035 (2 - 8ga) (phone 813-521-2700) and *AC Terminal* tool model 0280 (6 ga and larger) (phone 614-868-9828).

Testing and Troubleshooting

All Vanner equalizers fall into one of three distinct families. The three families operate differently and must be tested differently. The following three test procedures apply **only** to the equalizer family listed.

Before testing the equalizer, be sure all battery connections are good and that fuses F1 and F2 are good.

CAUTION

Servicing of electrical systems should only be performed by trained and qualified technical personnel.

Equipment Required

- VoltMeter having 0.01 volt resolution. (Fluke Model 87 Multimeter recommended).
- Clamp-on amp meter (Fluke Model 36 Clamp-on Meter recommended).

Vanner Repair Service

Vanner offers a quick turn around factory repair service for Family 1 and Family 2 models. (Family 3, 4 and 5 models are non-repairable.) Send the unit to the address below with a note instructing us to repair it. Include your name, phone number, shipping address (not a P.O. Box Number), and your purchase order number.

Test Procedure for Family 1 Battery Equalizers

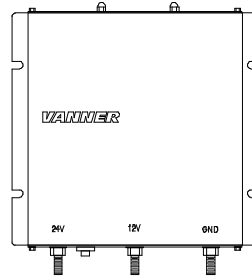

Models 60-10B, 60-20A, 60-50A

CAUTION

To avoid Reverse Polarity Damage to Family 1 and Family 2 Equalizers when servicing the electrical system or when performing any work which involves making battery connections always:

1. Remove Equalizer Ground terminal first.
2. Replace Equalizer Ground terminal last.

Family 1 Battery Equalizer Test Procedure:

1. Carefully remove the ground (GND) cable from the Equalizer. Do not allow this cable to touch any other connection on the Equalizer because the other terminals are connected to the batteries.
2. Make sure there is approximately 12 volts between the +24 and +12 terminals of the Equalizer by momentarily connecting the two terminals of a 12 volt light (headlight, marker light, etc.) to the +24 and +12 terminals of the Equalizer. The light should light and stay lit.
3. Next, connect that same 12 volt lamp between the +12 and GND terminals of the Equalizer. The lamp should light and stay lit. If the lamp does not light, the light then goes out, or the light dims, the Equalizer requires repair.
4. Further verification may be made by measuring the voltages on the Equalizer terminals. Be certain that the lamp used earlier is connected between the +12 and GND terminals.
5. Measure the voltage between +24 and +12 terminals. Note this reading.
6. Measure the voltage from the +12 terminal to GND. Note this reading.
7. Compare the two readings by subtracting the +12 to GND reading from the +24 to +12 reading. A properly functioning Equalizer is one where the difference is between -0.5 and +0.13 volts. For example, the +24 to +12 reading might be 12.85 volts. The +12 to GND voltage might read 12.75 volts. This Equalizer would be functioning properly with a 0.10 difference (12.85 minus 12.75 volts) which is within specs.

Common Questions for Family 1 Battery Equalizers

- Q) Will operating loads which exceed the output rating of the Battery Equalizer cause the circuit breaker (white button near the wiring terminals on Family 1 or Family 2 equalizers) to trip?

- A) No, the Battery Equalizer electronically limits the output current to a value less than the amount required to trip the circuit breaker. (Extreme conditions, such as 28 VDC input with 8 VDC output at very high ambient temperatures, may cause the circuit breaker to trip.)
- Q) Why is the Battery Equalizer's circuit breaker value lower than its output current rating (35 amp circuit breaker in model 60-50A)?
- A) The circuit breaker is in the ground circuit. Due to the equalizer's two to one (24/12 VDC) voltage conversion, the model 60-50A requires 25 amps at 24VDC input to produce about 50 amps output at 12 VDC. Therefore, a 35 amp circuit breaker in the GND circuit will properly protect for the maximum 25 amp rating.
- Q) What causes the circuit breaker to trip on a Battery Equalizer?
- A1) The Battery Equalizer's circuit breaker is designed to trip when the +12 volt toGND terminals are exposed to reverse polarity.
- A2) With the Battery Equalizer's GND terminal connected to chassis and the battery negative terminal disconnected, a short between a +24 volt circuit and chassis will pull the chassis up to +24 volts, causing a reverse polarity on the +12 volt to GND circuits. The circuit breaker trips to protect the Battery Equalizer.
- A3) With the Battery Equalizer's GND terminal connected to chassis and the battery negative cable disconnected, 24 volt loads (e.g., starter motor) will pull the chassis up to +24 volt causing a reverse polarity on the Battery Equalizer's +12 Volt toGND circuits. The circuit breaker will trip to protect the Battery Equalizer.
- A4) Since the above reverse polarity conditions may occur during bus maintenance it is recommended that the service personnel verify the circuit breaker is IN before releasing the bus for service and the tour bus operator do the same in his "walk around".
- Q) What are some known conditions that could cause Battery Equalizer problems?
- A1) Corrosive liquids or water forced into the Battery Equalizer's case from high pressure spray cleaning could shorten the normal life expectancy.
- A2) Drilling into the case (except for the mounting flanges) can shorten the life or prevent the unit from operating. The installer may not realize the Battery Equalizer is not operating correctly unless a 12 volt load is applied to the system and the Battery Equalizer 12 volt current is measured.
- A3) Too small of wire or bad connections will allow the Battery balance to be less than optimum. Voltage loss in wire from the battery's +24 volt terminal to the Battery Equalizer's +24 volt terminal should be 0.05 VDC maximum; from the battery's +12 volt terminal to the Battery Equalizer's +12 volt terminal should be 0.10VDC maximum, and from the battery ground terminal to the Battery Equalizer's GND terminal should be 0.05 VDC maximum, when the +12 volt load is causing the Battery Equalizer to operate at 100% capacity.
- A4) Installing the Battery Equalizer in a location where it will be exposed to battery fumes will shorten its normal life. Acid fumes are heavier than air. Installation of Battery Equalizers on the battery mounting surface near the bottom of the batteries have caused severe corrosion to the Battery Equalizers. However, installation of Battery Equalizers 3 or more inches above the top of the batteries have not caused problems.
- Q) Can different models of equalizers be paralleled?
- A) Yes, any combination of models from Family 1, Family 3 and Family 4 may be paralleled. Family 2 models may only be paralleled with other Family 2 models.

Test Procedure for Family 2 Battery Equalizers

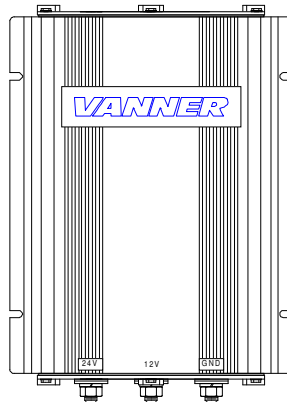

Models 60-100C, 60-100D and 60-100E

General: Family 2 Equalizers were designed to be more energy conservative during low power requirements compared to Family 1 models. This along with unique protection circuitry require Family 2 models to be tested differently than Family 1, or Family 3, 4 and 5 models.

CAUTION

To avoid Reverse Polarity Damage to Family 1 and Family 2 Equalizers when servicing the electrical system or when performing any work which involves making battery connections always:

1. Remove Equalizer Ground terminal first.
2. Replace Equalizer Ground terminal last.

Family 2 Battery Equalizer Test Procedure:

1. With the coach engine and vehicle loads OFF measure the voltage of Battery A. Replace or recharge Battery A if less than 11.5 volts.
2. Start the engine and turn ON a 12 volt load such as headlights.
3. Measure the input voltage between the +24 and GND posts of the equalizer. This voltage should be between 25.5 volts and 29.0 volts. If it isn't then check the alternator and 24 volt voltage regulator circuits.
4. Zero the DC Clamp-on ammeter as needed.
5. Put the jaws of the clamp-on ammeter around all wires connected to the equalizer +12 volt terminal stud.
6. Observe the DC amperage out of the equalizer with the clamp-on ammeter. If there are 3 amps or more showing on the ammeter, the equalizer is functioning and no further tests are needed.
7. Continue with the following steps ONLY if the ammeter shows less than 3 amps.
8. Measure the voltage between the +24 terminal (meter positive lead) and the +12 terminal (meter negative lead) of the equalizer. Record this voltage.
9. Subtract 0.60 volts from the number recorded in Step 8.
10. Measure the voltage between the equalizer +12 terminal (meter pos) and the GND terminal (meter neg).
11. Wait for this voltage to drop below the voltage calculated in Step 9 or the clamp-on ammeter reading jumps from approximately 0 to more than 3 amps. More than 3 amps means the equalizer is functioning.

- If the voltage drops below the calculated value from Step 9 and the clamp-on ammeter has not jumper from approximately 0 to more than 3 amps of current wait for an additional 30 seconds.
- If the equalizer does not turn ON after 30 seconds the unit is defective and should be sent in for repair.

Test Procedure for Family 3, 4 & 5 Battery Equalizers

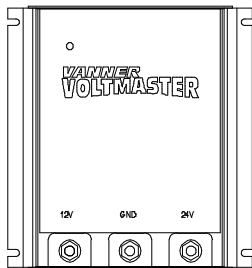

Models 60-60, 60-80 and 60-100



Models 65-60, 65-80, 65-100
Models 66-60-66-80, 66-100

General: Family 3, Family 4 and Family 5 Equalizers contain an indicator light. If the indicator light is ON the equalizer is working.

The Equalizer is working properly if:

- The Indicator Light is ON and;
- The 12 volt DC loads are being operated continuously and are within the rated capacity of the equalizer and;
- Battery A voltage is lower than Battery B by no more than 0.05 to 0.10 volts (measured at the equalizer +24, +12 and GND terminals).

Family 3, 4 and 5 Battery Equalizers are electronically protected against reverse polarity damage therefore the DC connection sequence is not an issue.

Family 3, 4 and 5 Equalizers will not function properly unless all three battery connections are made. Battery A and Battery B voltages both must be above 8 volts for the unit to turn ON.

Any combination of Family 1, Family 3, Family 4 and Family 5 models may be operated in parallel.

Please note that the 24V, 12V and GND stud position and orientation are different on Family 3, 4 and 5 models than on Family 1 or Family 2 models.

Family 3, Family 4 and Family 5 Battery Equalizer Test Procedure:

- Field test the equalizer while fully connected to the vehicle batteries. For bench testing, two 12 volt batteries, or two 12 volt power supplies are required. Family 3, 4 and 5 Equalizers must be connected to the batteries at GND, 12V and 24V to function properly.
- If battery voltage is below 24 volts start the vehicle or apply a 24 volt battery charger to the batteries.
- Turn ON 12 volt DC loads up to the equalizer rated capacity. Measure DC amps on the equalizer +12 cable to verify load amperages.
- At the equalizer** measure and record:
 - Battery A voltage (voltage between the equalizer +12 and GND terminals)
 - Battery B voltage (voltage between the equalizer +24 and +12 terminals)
 - Equalizer Indicator Light status (ON or OFF)

5. Subtract Battery A voltage from Battery B voltage and compare readings.

Voltage Comparison		Indicator Light	Equalizer Status	
a.	Battery A is lower than Battery B but within 0.05 volt.	OFF	OFF	Stand-by Mode. The equalizer will not turn ON until Battery A is lower than Battery B by more than 0.05 volts.
b.	Battery A is lower than Battery B by 0.05 to 0.10 volts.	ON	ON	Normal Operating Mode
c.	Battery A is lower than Battery B by more than 0.10 volts	ON	ON	Self-Protection Mode due to Overload Condition. See below.
d.	Battery A is lower than Battery B by more than 0.10 volts	OFF	OFF	The Equalizer is not functioning properly.
e.	Battery A is <u>higher</u> than Battery B	Abnormal condition. Suspect Battery B is defective or a 12 volt load is connected to Battery B.		

Overload Condition on Family 3, Family 4 and Family 5 Equalizers

An overload condition exists when the 12 volt loads exceed the equalizer's rated capacity. The overload condition will not damage the equalizer but may cause damage to the batteries.

During the overload, the equalizer output is limited by internal protection circuits to its Rated Output Amps. The 12 volt amps exceeding the equalizer output are drawn from Battery A which will begin to draw the batteries out of balance. The equalizer full Rated Output Amps are maintained as long as Battery A and Battery B remain balanced within 0.10 volt. The internal protection circuits will reduce equalizer output as the batteries become further out-of-balance. If Battery A voltage falls below approximately 8 volts the equalizer will shut itself OFF.

To correct the overload condition the 12 volt load must be reduced or the equalizer capacity must be increased.

Trouble Shooting an Engine No-Start Situation

Situation:

A coach has dead batteries and won't start while jump starting. The coach is equipped with a 24 volt starting and charging system, a 12 volt electronic diesel engine control, a Family 3, 4 or 5 Equalizer, and a moderate 12 volt load which cannot be turned OFF. The coach sits for several days and the batteries run completely dead. During jump starting the engine cranks but does not start due to low voltage on the 12 volt supply. Electrical testing reveals there is no 12 volt output from the equalizer while jump starting even though the equalizer separately tests OK.

Cause:

The 12 volt load which could not be turned OFF first ran both batteries down until the equalizer shut itself OFF due to low voltage. (Family 3, 4 and 5 Equalizers will shut OFF if system voltage falls below 16 volts or if voltage on either battery falls below 8 volts.) Then Battery A alone was drained to near zero volts. As the bus is being jumped, 12 volt loads hold Battery A voltage too low for the equalizer to turn ON and Battery A is too weak to support the 12 volt electronic engine control.

Solution:

Turn OFF all 12 volt loads (turning the battery disconnect switch OFF may accomplish this). Connect the jumper cables but do not crank the engine for two or three minutes or until the equalizer indicator light has turned ON which means the equalizer is ON. (Both batteries must rise above 8 volts.) The battery disconnect switch can then be turned ON and the bus should have adequate 12 volt power to start.

Vanner Incorporated
4282 Reynolds Drive
Hilliard, Ohio 43026

1-800-AC POWER
(1-800-227-6937)
Tel: 614-771-2718
Fax: 614-771-4904

www.vanner.com
e-mail: pwrsales@vanner.com

Part Number D98761
July 15, 2002 Printed in U.S.A.